

# Industrial Catalogue

TRANSFORM YOUR WORKSPACE



AUTO  
TRANSFORM  
Engineered Vehicle Innovation





**Your trusted fleet partner with over 31 years of experience transforming commercial vehicles to maximise safety, productivity and return on investment.**

# Contents

## About Us

Our Promise to You .....	4
About Auto Transform .....	5

## Standard Vehicle Fitouts

Ute Canopy Fitouts .....	6
Service Body Fitouts .....	9
Van Fitouts .....	15
Truck Body Fitouts .....	22

## Service Bodies & Flat Decks

3 Way Tippers .....	25
Ute Flat Decks .....	27
Ute Canopies .....	30
Ute Service Bodies .....	31
Truck Flat Decks .....	33
Truck Service Bodies .....	34

## Modular Storage Systems

Syncro System .....	36
Cupboard Storage Units .....	42
Trade System+ Drawers .....	44
Trade System Shelving & Accessories .....	47

## Parts & Accessories

Van Linings .....	51
Underdeck Accessories .....	53
Roof Racks & Accessories .....	56
Glass Transport .....	60
Safety Barriers .....	61
External Accessories .....	63
Cab Accessories .....	66
Internal Accessories .....	68
General Accessories .....	69
Cranes .....	71
Windows .....	72
Electrical .....	73

## OUR PROMISE TO YOU

# Transform your vehicle and maximise:

### Safety

#### Crash Tested

- ✔ The only crash tested product in New Zealand
- ✔ Surety of increased safety and protection for your drivers in case of an accident.
- ✔ Peace of mind that your tools are well secured.
- ✔ Tools in drawers are fully secure and will not fly around the vehicle.

#### Security

- ✔ Full integrated central locking on service body ensuring your expensive gear is completely secure on and off site with one push of your lock button on your key FOB.
- ✔ Alarm sensors integrated into each door
- ✔ Doors are flush with side pillars making it harder to pry open

### Productivity

#### Smart Design

- ✔ Professional storage system ensures a place for every part maximising your efficiency
- ✔ Proven to save you a minimum of 30mins a day x 5 days p/wk = 2.5hrs p/wk x 50 weeks p/yr = 125hrs p/year x \$60 p/hr = \$7,500 p/yr.
- ✔ Split door unit increases interior storage capacity while allowing for a work bench area, maximising efficiency on the job

#### Modular Design

- ✔ Professional storage system is 100% modular ensuring increased storage effectiveness - maximising capacity and efficiency.

### Return on Investment

#### Quality and Durability

- ✔ Professional storage system ensures a place for every part maximising your efficiency
- ✔ Proven to save you a minimum of 30mins a day x 5 days p/wk = 2.5hrs p/wk x 50 weeks p/yr = 125hrs p/year x \$60 p/hr = \$7,500 p/yr.
- ✔ Split door unit increases interior storage capacity while allowing for a work bench area maximising efficiency on the job

#### Generate Revenue Faster

- ✔ Holding stock of modular product and with our service orientated process, and compete one-stop-shop offering, we ensure you get your vehicle on the road within one month from order and into service generating revenue for you.

### Service you can depend on

Before you build, throughout the build and after the build. We stand behind all our work with over 50 service agents nationwide, including full time service tech, to minimise your downtime and ensure your fitout is always working for you.



## ABOUT AUTO TRANSFORM

# NZ's leading vehicle customisers

Established in 1990, Auto Transform is a New Zealand owned family business based at a purpose-built facility in Wiri, Auckland.

We've built our success from the ground up by consistently delivering superior transformations for commercial, passenger and mobility vehicles. In the sphere of automotive customisation in New Zealand, we're known as innovators who work from a solid foundation of product knowledge and real-life experience.

- ✔ No job too big, too small or too difficult
- ✔ From one-off vehicles to full fleets
- ✔ Expert in-house designers working with 3D CAD
- ✔ Solutions for all budgets, from economy to luxury
- ✔ Market-leading technology at every stage
- ✔ End-to-end project management
- ✔ Under-one-roof implementation for quick turnaround
- ✔ ISO 9001, 14001 and 45001 accredited
- ✔ 5 year conditional guarantee



### 100% NZ Owned & Operated

We're a Kiwi-owned business providing world-class vehicle solutions. When you fit out your vehicle with us, you're supporting a local family business.

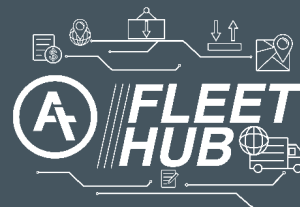

### AT Fleet Hub

Transform your fleet management with AT Fleet Hub. Built to maximise your convenience and simplify your build management.

# Ute Canopy Fitouts

## What makes our Dynamic Pro Canopies different?

If you're needing a highly functional canopy that provides great access, is strong, secure and looks great, the Dynamic Pro is what your looking for.



### Strongest canopy in the market

TUV Crash tested. Fibreglass construction with steel reinforcement provides maximum durability over 10 years. The only canopy with 110kg load rating on the roof.



### Maximum access and maximum efficiency

The unique full side door provides access like no other which in turn maximises your efficiency on the job, and your effectiveness on the job. Our single handle paddle latch and full central locking on all doors also makes loading and unloading more convenient, safer, and more efficient.



### The safest canopy for your gear

With the flush gullwing door design, touch pad central locking, and closed side panels, there is no other canopy as safe as this to protect your valuable gear.



### Boost your image

Thanks to an optimal style and design the dynamic pro canopy looks tough and compliments the vehicle. Furthermore, the sides of the closed and fold-up version are perfectly suited as an advertising medium.



Dynamic canopy pro with ladder rails



Faults Tech Canopy Fitout

# Ute Canopy Fitouts

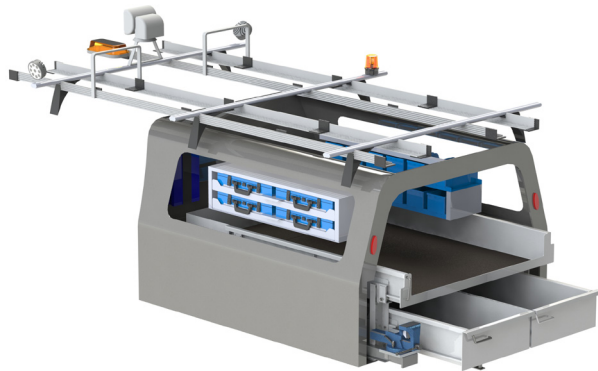

## Faults Tech

C-FAULTS



Dynamic Pro+ canopy, Double AT drawer system, Vice slide, 4 x pull-out consumable cases, Double shelf unit, Double extension ladder-rack, 2 x spot lights, Remote spot light, LED beacon Front, 2 x slimline beacons rear

- ✓ Maximised capacity
- ✓ Efficient workspace
- ✓ Crash tested
- ✓ Secure central locking

<b>Weight</b>	256kg
<b>Load Capacity</b>	1200kg
<b>Composition</b>	30% Fibre Glass, 60% Alloy, 5% Steel, 5% Grip Ply

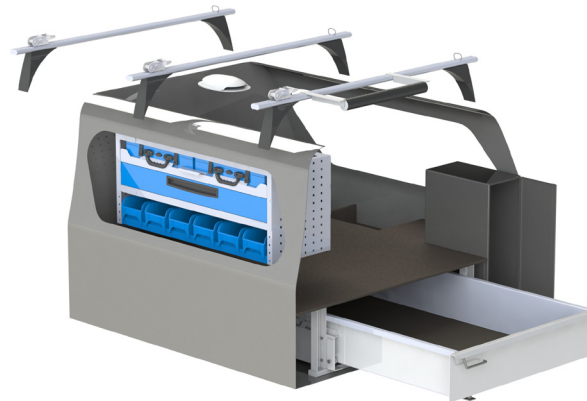

## HVAC Tech

C-HVAC



Dynamic Pro+ Canopy, Single AT drawer system, 2 x pull-out consumable cases, Bin shelf unit, Oxy-acetylene vented/sealed cabinet, Boxed out RHS storage over wheelarch

- ✓ Ergonomic work zone
- ✓ Best HVAC storage
- ✓ Maximised access
- ✓ Maximised efficiency

<b>Weight</b>	174kg
<b>Load Capacity</b>	1076kg
<b>Composition</b>	30% Fibre Glass, 50% Alloy, 10% Steel, 10% Grip Ply

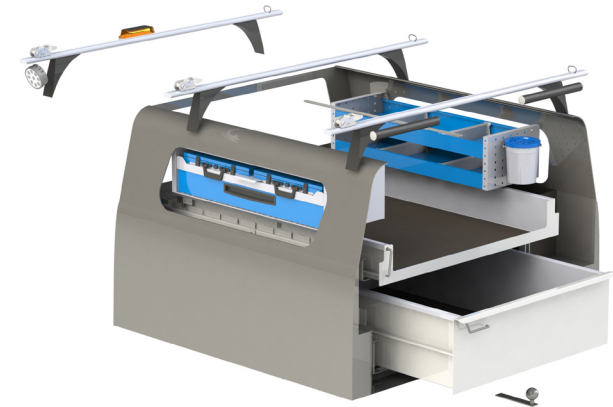

## Electrical & Security

C-ELECSEC



Dynamic Pro+ canopy, Double AT drawer system, 2 x pull-out consumable cases & side drawer, Double shelf unit, Roof rack & accessories, LED flood light & beacons, hygiene kit

- ✓ Place for every part
- ✓ Maximised efficiency
- ✓ Easy accessibility
- ✓ Secure central locking

<b>Weight</b>	201kg
<b>Load Capacity</b>	1049kg
<b>Composition</b>	30% Fibre Glass, 60% Alloy, 5% Steel, 5% Grip Ply

# Ute Canopy Fitouts

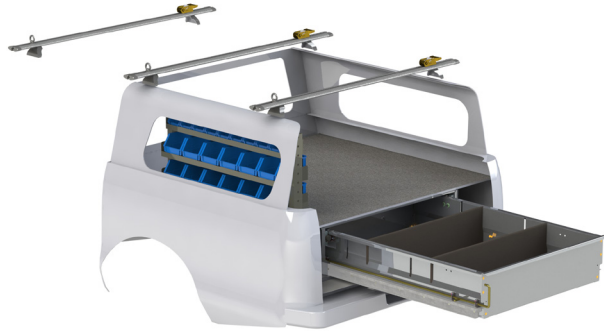

## Tradesman 1

C-TRADE1



Dynamic Pro+ canopy, Single AT drawer system with fixed false floor, 3 tier shelving LHS, Roof racks & accessories

- ✓ Economically practical
- ✓ Functional storage
- ✓ Secure central locking
- ✓ Deep case storage

<b>Weight</b>	169kg
<b>Load Capacity</b>	1081kg
<b>Composition</b>	30% Fibre Glass, 40% Alloy, 15% Steel, 15% Grip Ply

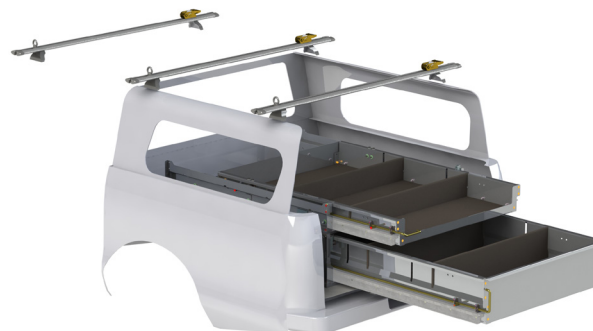

## Tradesman 2

C-TRADE2



Dynamic Pro+ canopy, Double AT drawer system, Roof racks & accessories

- ✓ Maximised accessibility
- ✓ Safe & secure tools
- ✓ Efficient workspace
- ✓ Ergonomic work zone

<b>Weight</b>	178kg
<b>Load Capacity</b>	1072kg
<b>Composition</b>	30% Fibre Glass, 40% Alloy, 15% Steel, 15% Grip Ply

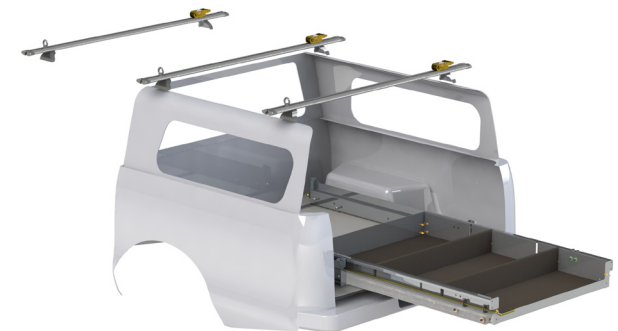

## Tradesman 3

C-TRADE3



Dynamic Pro+ canopy, AT slide out platform, Roof racks & accessories

- ✓ Great bulky storage access
- ✓ Safe storage
- ✓ Maximised capacity
- ✓ Economically practical

<b>Weight</b>	143kg
<b>Load Capacity</b>	1107kg
<b>Composition</b>	30% Fibre Glass, 40% Alloy, 15% Steel, 15% Grip Ply



# Service Body Fitouts

## What are the key benefits of a Service Body?

This is the most modular, and functional service body in the world. Designed to look tough, maximise strength and payload, minimise weight, and drive your efficiency - there is no doubt this is the best on the market.



### Increased payload

Auto Transform Aluminium Service Bodies are unmatched when it comes to maximising your payload capacity. Proven to be at least 10% lighter than other Aluminium decks, you can be sure you'll be able to carry all the tools you need to be highly efficient in a day and incorporate our compatible storage modules without exceeding your weight limit.



### Strongest service body in the market

3mm aluminium construction with folds instead of welds, to avoid cracking in areas where there is extra stress. Riv-nuts and bonding (aeroplane construction methodology) to provide maximum durability over 10 years. The universality of the mounting means it can re-fitted onto any other make or model available.



### Best work area to give the greatest efficiency

Our unique split side door provides an excellent workbench, which in turn maximises your efficiency on the job, and your capacity inside the service body. Our single handle paddle latch and full central locking on all doors also makes loading and unloading more convenient, safer and more efficient.



### Most modular shelving and drawers

Our modular shelving and drawer systems can all be fully interchanged, meaning you can maximise your capacity and segregate your tools and equipment like none other.



**“It just really makes it easier to do my job and takes the strain and the stress out of it.”**

Mitch, Watercare

# Full Service Body Fitouts

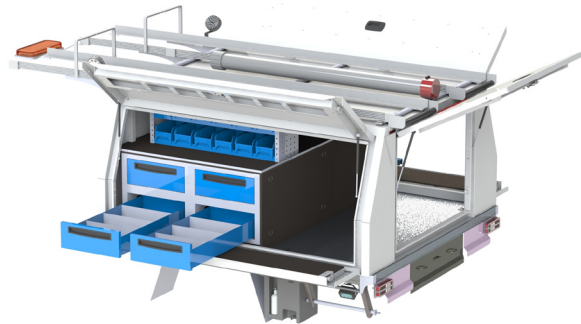

## Electrical Fitter

FSB-ELECT



Full service body with 2 x integrated split door work bench, modular Syncro drawers x 4 and 2 tiers shelves with bins, underdeck drawer, 15L Water container with soap, LED warning lights, 2 x Extension ladder racks, Fold out vice, underdeck battery mounting & 3000W inverter

- ✓ Maximised efficiency
- ✓ Storage for small and large parts
- ✓ Ergonomic work zone
- ✓ Commercial grade & lightweight

<b>Weight</b>	520kg
<b>Load Capacity</b>	1030kg
<b>Composition</b>	20% Steel, 70% Alloy, 10% Grip ply

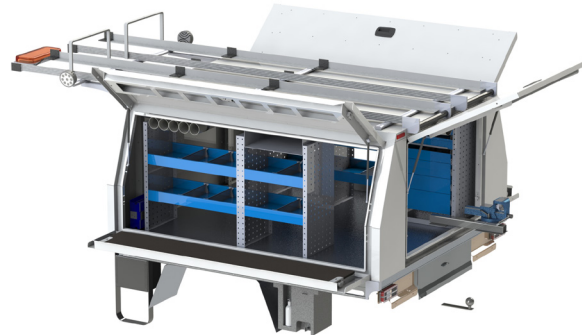

## Faultsman 1

FSB-FAULTS1



Full service body with 2 x integrated split door work bench, Modular Syncro open shelving, 2 Pull out cases, 4 Small drawers, Underdeck drawer, 15L Water container with soap, LED Warning lights, Spot lights, 2 x Extension ladder racks, Slide out vice, Underdeck battery mounting & 2000W inverter

- ✓ Easy efficient access
- ✓ Maximised accessibility
- ✓ Safe workspace
- ✓ Durable

<b>Weight</b>	523kg
<b>Load Capacity</b>	1027kg
<b>Composition</b>	10% Steel, 80% Alloy, 10% Grip ply

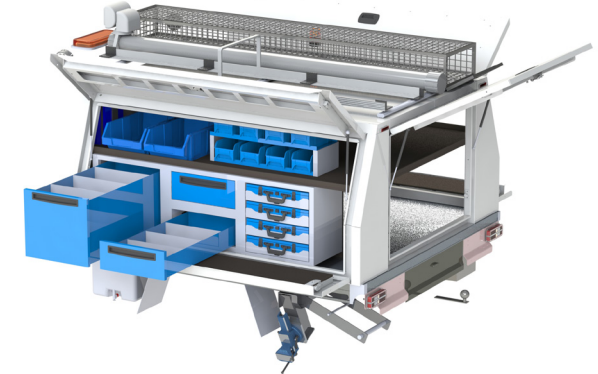

## Faultsman 2

FSB-FAULTS2



Full service body with 2 integrated split door work bench, 3 modular Syncro drawers, 2 tier shelves with bins, 4 pull out cases & small drawer, False floor, Underdeck drawer, 15L Water container, LED warning lights, Spotlights, Remote spot light, Extension ladder rack & cage, Fold out vice, Underdeck battery mounting & 2000W inverter

- ✓ Maximised capacity
- ✓ Ergonomic work zone
- ✓ Place for every part & tool
- ✓ Greater ROI

<b>Weight</b>	583kg
<b>Load Capacity</b>	967kg
<b>Composition</b>	25% Steel, 65% Alloy, 10% Grip ply

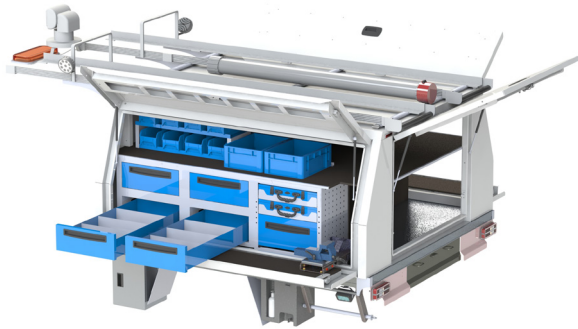

### Faultsman 3

FSB-FAULTS3



Full service body with 2 integrated split door work bench, 4 drawers, 2 tiers shelves with bins, Pull out cases & small drawer, False floor, Underdeck drawer, 15L Water container, LED warning lights, Spotlights, Remote spot light, 2 Extension Ladder Racks, Fold out vice, Underdeck battery mounting & 3000W inverter, 4kg gas box

- ✓ Place for every part
- ✓ Ergonomic work zone
- ✓ Maximised efficiency
- ✓ Maximised access

<b>Weight</b>	565kg
<b>Load Capacity</b>	985kg
<b>Composition</b>	20% Steel, 70% Alloy, 10% Grip ply

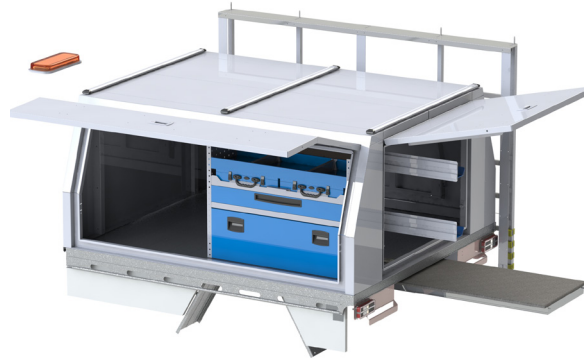

### Glazier

FSB-GLAZIER



Full service body with Gull wing door, Internal modular Syncro drawers, Cases, Open shelving, Slide out hooks, Slide out underdeck table, 3 bar roof rack, Warning beacon, Removeable glass frail unit

- ✓ Highly functional workspace
- ✓ Total flexibility
- ✓ Modular storage
- ✓ Maximised efficiency

<b>Weight</b>	344kg
<b>Load Capacity</b>	906kg
<b>Composition</b>	20% Steel, 70% Alloy, 10% Grip ply

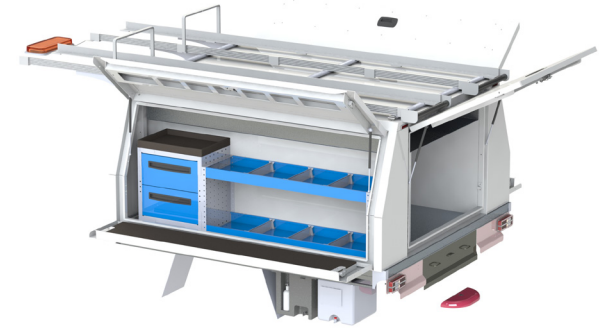

### Lines Tech

FSB-LINESTECH



Full service body with split doors, internal Modular Syncro drawers, Underdeck drawer, 2 x Extension Ladder Racks, warning beacon, Segregated internal storage panels, 15L Water Container with soap, 20L Emergency water, Safe-T-Step

- ✓ Easy efficient access
- ✓ Segregated safe workspace
- ✓ Efficient workspace
- ✓ Commercial grade & lightweight

<b>Weight</b>	436kg
<b>Load Capacity</b>	1114kg
<b>Composition</b>	10% Steel, 80% Alloy, 10% Grip ply

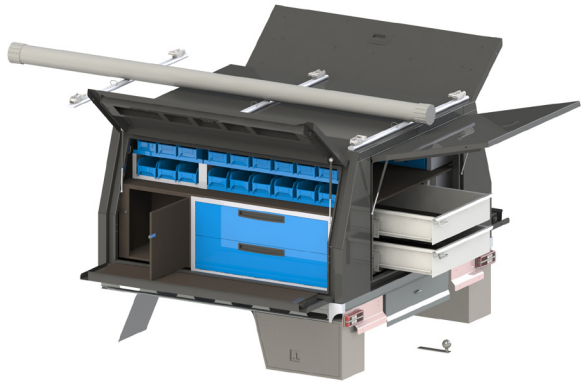

## Plumber

FSB-PLUMBER



Full service body with split doors, Internal modular Syncro drawers and shelving with bins, Underdeck drawer, 3 bar roof racks, False floor, 2 x deep AT Drawers out rear, Under deck boxes

- ✓ Maximised capacity
- ✓ Easy access
- ✓ Efficient workspace
- ✓ Durable

<b>Weight</b>	461kg
<b>Load Capacity</b>	789kg
<b>Composition</b>	25% Steel, 65% Alloy, 10% Grip ply

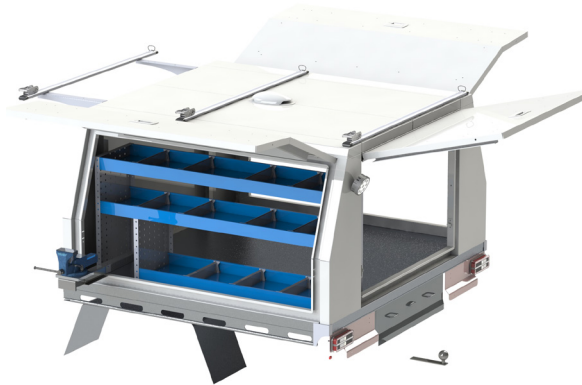

## Tradesman

FSB-TRADE



Full Service Body with gullwing doors, Modular Syncro open shelving with dividers, Slide out vice, Underdeck drawer, Rear flood light, 3 bar roof rack with ratchets & eyebolts, Roof vent

- ✓ Great bulky storage access
- ✓ Safe storage
- ✓ Maximised capacity
- ✓ Economically practical

<b>Weight</b>	278kg
<b>Load Capacity</b>	972kg
<b>Composition</b>	10% Steel, 90% Alloy



## Water Tech

FSB-WATER



Full service body with gullwing doors, Modular Syncro drawers x 4, Small drawers x 4, Large lockable cabinet, LED slimline warning lights x 4, Hygiene kit, Underdeck drawer, Rear flood light, 3 bar roof rack

- ✓ Place for every tech's part & tool
- ✓ Ergonomic work zone
- ✓ Maximised efficiency
- ✓ Maximised access

<b>Weight</b>	475kg
<b>Load Capacity</b>	775kg
<b>Composition</b>	25% Steel, 65% Alloy, 10% Grip ply

# Tool Box Service Body Fitouts

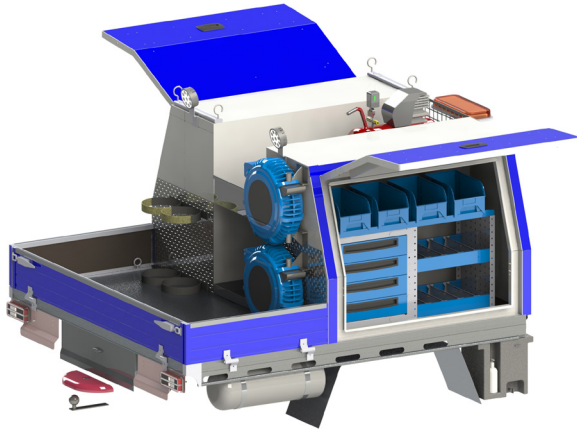

## Diesel Mechanic 1

TBSB-DIEMECHA2



Service body tool boxes x 2 on heavy duty alloy flat deck, Grip plywood inserts, Underdeck box and drawer, Centre pull out shelf for oil containment, Compressor centre mount, 1000W inverter, LED beacon & flood lights, Oxyacetylene & air hose reels, Modular Syncro drawers & shelves, Fold out vice

- ✓ Place for every mechanic's part & tool
- ✓ Ergonomic work zone
- ✓ Maximised efficiency
- ✓ Maximised access

<b>Weight</b>	492kg
<b>Load Capacity</b>	1058kg
<b>Composition</b>	30% Steel, 60% Alloy, 10% Grip ply

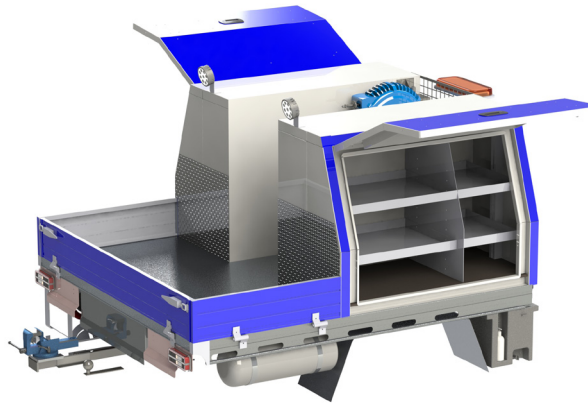

## Diesel Mechanic 2

TBSB-DIEMECHA2



Service Body Tool boxes x 2 on heavy duty alloy flat deck, Adjustable shelves, Underdeck drawer, Compressor, Underdeck mount, 1000W inverter, LED beacon and flood lights, Air hose reels, Slide out vice

- ✓ Ergonomic work zone
- ✓ Safe workspace
- ✓ Easy efficient access
- ✓ Safe storage

<b>Weight</b>	460kg
<b>Load Capacity</b>	1090kg
<b>Composition</b>	20% Steel, 70% Alloy, 10% Grip ply

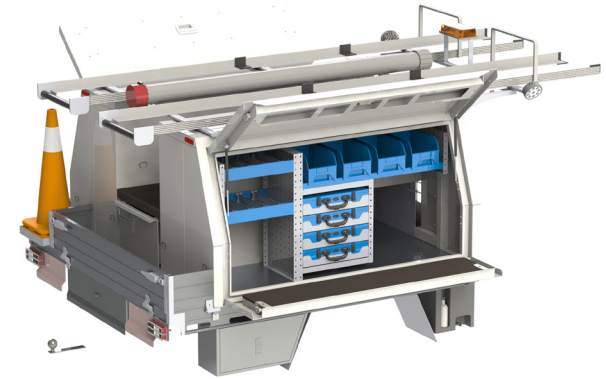

## Faults Tech

TBSB-FAULTSA



Service body 1720 tool boxes x 2 on heavy duty alloy flat deck, Grip plywood inserts, Underdeck box and drawer, Centre pull out drawer and shelf, LED beacon & spot lights, Extension ladder rails x 2 and 3m conduit pipe, Modular syncro drawers and shelves, Fold out vice, Fold out cone holder

- ✓ Place for every tech's part & tool
- ✓ Ergonomic work zone
- ✓ Maximised efficiency
- ✓ Maximised access

<b>Weight</b>	533kg
<b>Load Capacity</b>	1017kg
<b>Composition</b>	25% Steel, 65% Alloy, 10% Grip ply

# Tool Box Service Body Fitouts

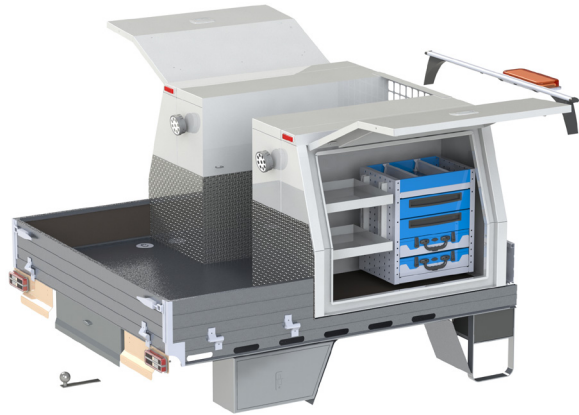

## Service Tech

TBSB-SERVTA



Service Body tool boxes x 2 on heavy duty alloy flat deck, Adjustable shelves, Modular Syncro drawers & cases, Underdeck box and drawer, 2000W inverter, LED Beacon, Warning lights & flood lights

- ✓ Safe workspace
- ✓ Efficient workspace
- ✓ Durable
- ✓ Lightweight

<b>Weight</b>	410kg
<b>Load Capacity</b>	1140kg
<b>Composition</b>	20% Steel, 70% Alloy, 10% Grip ply



**“Communication has been first class, product is very good, and most importantly the end users are all happy with the vehicles”**

Unison Contracting Services

# Van Fitouts

## Commercial van fitouts that benefit your business by supporting productive days, on and off the road.

We understand how the design of storage, carrying frames, security features, workbenches, on-board power and lighting can all contribute to the safety and efficiency of your van. We also understand the importance of well-engineered components with a strong professional finish. They not only work harder, they speak volumes about your business.



### Increased payload

Auto Transform Van fit-outs are unmatched when it comes to maximising your payload capacity. Proven to be at least 40% lighter thanks to the cut-through design, you can be sure you'll be able to carry all the tools you need to be highly efficient in a day with the modular storage modules without exceeding your weight limit.



### Maximised efficiency through functionality

With our range of modular products, we maximise your efficiency by a minimum of 10% in a day. Designed with interchangeable dividers, slam latches, and high quality modular components you'll notice the time saving immediately.



### Crash tested

All our modular product is crash tested so your drivers and technicians can be assured of their safety from tools in case of an accident.



### Most modular shelving & drawers

Our modular shelving and drawer systems can all be fully interchanged, meaning you can maximize your capacity and segregate your tools and equipment like none other.



**“Auto Transform offers the best solutions & quality product making our vehicle fleet more efficient to work from. They provide exceptional service to Argus Fire Protection. We highly recommend them.”**

Bryce Donaldson, General Manager, Argus Fire Protection

# Small Van Fitouts

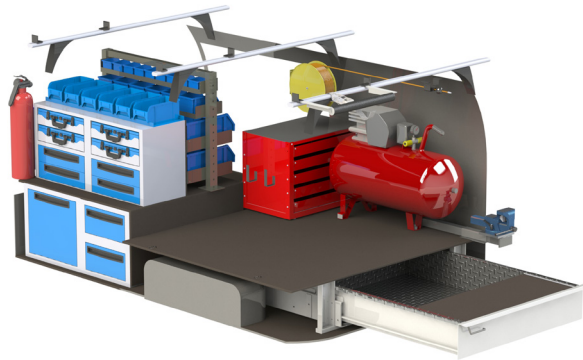

## Diesel Mechanic

SV-DIESEL



Front bulkhead barrier, Syncro System LH side door 950mmD drawer x 3, 350mmD tool drawers x 4, Pullout parts cases x 4, Bin shelf, TS150 shelving, RHS single large AT drawer, Vice & slide unit, Compressor & hose reel, 3 bar HD roof rack, Ladder roller, Grip plywood liner, 1500W inverter, LED interior light

- ✔ Place for every mechanic's part & tool
- ✔ Maximum job efficiency
- ✔ Ergonomically safe workzone
- ✔ Commercial grade

<b>Weight</b>	394kg
<b>Load Capacity</b>	700kg
<b>Composition</b>	40% Steel, 40% Alloy, 20% Grip ply

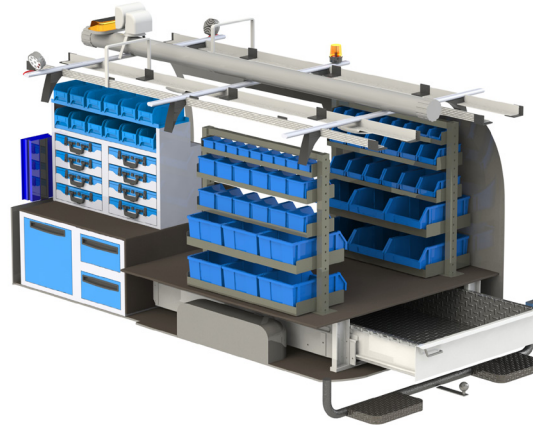

## Electrical Faultsman

SV-ELECFA



Modular Syncro System drawers x 3, Pullout parts cases & bin shelves, TS150 shelving, AT drawer out rear, Grip plywood linings, Vice & slide unit, Roof rack with ladder rails, Power kit, LED interior light, Warning beacons, Spot light & remote spot, Rear step & towbar

- ✔ Easy efficient access
- ✔ Ergonomically safe workzone
- ✔ Maximum job efficiency
- ✔ Maximised payload & capacity

<b>Weight</b>	428kg
<b>Load Capacity</b>	670kg
<b>Composition</b>	30% Steel, 50% Alloy, 20% Grip ply



## Electrical Fitter

SV-ELECFI



TS150 shelving rear, Grip plywood linings, Vice & slide unit, Roof racks with dual extension ladder racks, 3m x 100mm conduit pipe, Power kit, LED interior light, warning beacons, Rear step and towbar

- ✔ Economically practical
- ✔ Functional storage
- ✔ Maximised access
- ✔ Efficient workspace

<b>Weight</b>	250kg
<b>Load Capacity</b>	850kg
<b>Composition</b>	50% Steel, 20% Alloy, 30% Grip ply



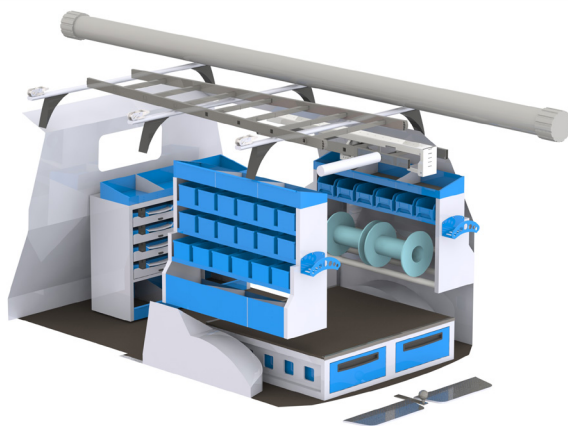

## Fire Alarm Tech

SV-FIREAT



Modular Syncro System drawers x 2, Pullout parts cases, Open shelves & bin shelves, Electrical conduit roll holder, 2 x extension lead holder, Grip plywood linings, Roof rack with tie-down accessories, LED interior light, Internal jet rack ladder holder, Rear step & towbar

- ✓ Place for every tech's part and tool
- ✓ Easy efficient access
- ✓ Ergonomic work zone
- ✓ Commercial grade

<b>Weight</b>	263kg
<b>Load Capacity</b>	837kg
<b>Composition</b>	50% Steel, 30% Alloy, 20% Grip ply

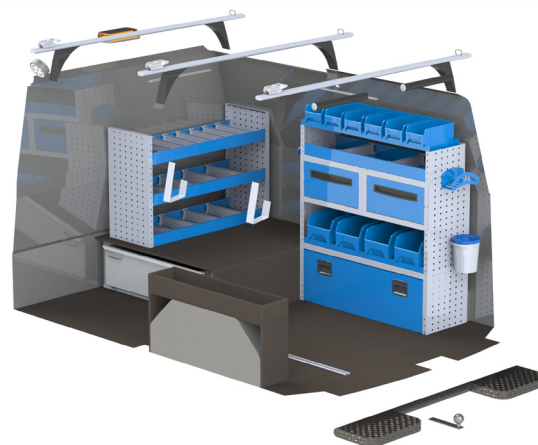

## Fire Sprinkler Tech

SV-FIREST



Modular Syncro System open shelves, Bin shelves, 2 large side drawers, Over wheelarch storage, 1 x extension lead holder, Hygiene kit, Grip plywood linings, Wheelarch storage, Roof rack with tie-down accessories, LED interior lighting, Beacon & work light, Rear step & towbar

- ✓ Easy efficient access
- ✓ Designed to maximise job efficiency
- ✓ Place for every part
- ✓ Safe workspace

<b>Weight</b>	220kg
<b>Load Capacity</b>	880kg
<b>Composition</b>	50% Steel, 30% Alloy, 20% Grip ply

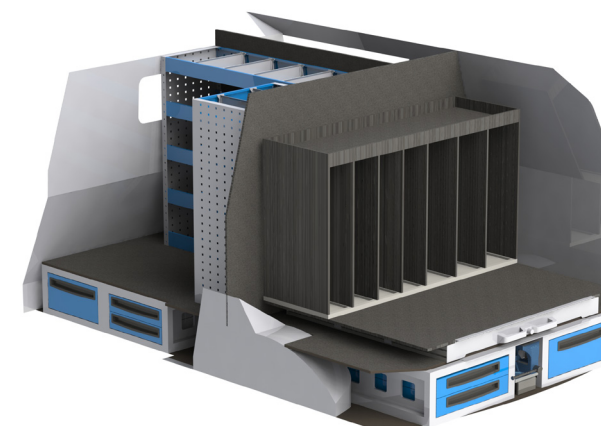

## Hose Doctor

SV-HOSED



Modular Syncro System side and rear drawers, Open shelving with multiple dividers to maximise part segregation, Pull out rear platform with hose rack, Grip plywood linings, LED interior lighting

- ✓ Maximised capacity
- ✓ Efficient workspace
- ✓ Safe workspace
- ✓ Durable

<b>Weight</b>	310kg
<b>Load Capacity</b>	790kg
<b>Composition</b>	50% Steel, 30% Alloy, 20% Grip ply

# Small Van Fitouts

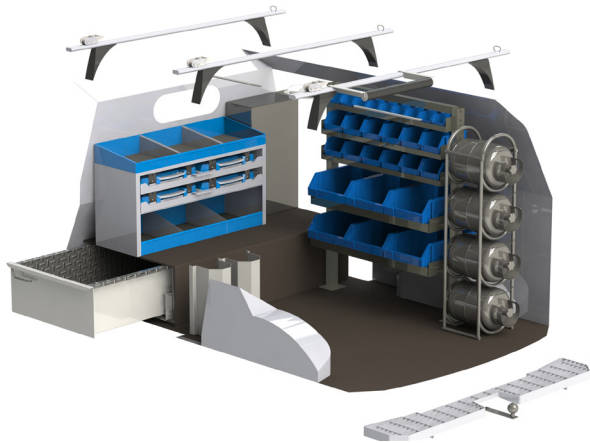

## HVAC Tech

SV-HVAC



Modular Syncro System open shelves & 4 pull-out tool cases, large AT Side dual directional drawer, TS150 5 Tier shelving kit, Grip plywood linings, Roof rack with tie-down accessories, Oxy-acetylene vented cabinet, D-size and refrigerant Gas bottle holders, LED interior lighting, Rear step and towbar

- ✔ Ergonomic work zone
- ✔ Best HVAC storage
- ✔ Maximised access
- ✔ Maximised efficiency

<b>Weight</b>	218kg
<b>Load Capacity</b>	882kg
<b>Composition</b>	50% Steel, 30% Alloy, 20% Grip ply

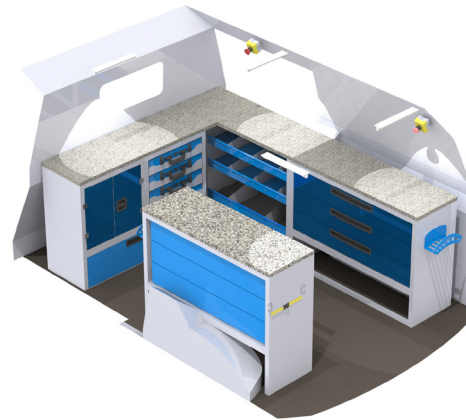

## Locksmith

SV-LOCKS



Modular Syncro System open shelves, drawers & 4 pull-out tool cases, Grip plywood linings, 240V Electrical outputs with 2000W inverter and back-up battery, LED interior lighting

- ✔ Place for every locksmith's part & tool
- ✔ Efficient workspace
- ✔ Safe & secure tools
- ✔ Commercial grade

<b>Weight</b>	240kg
<b>Load Capacity</b>	860kg
<b>Composition</b>	60% Steel, 20% Alloy, 20% Grip ply

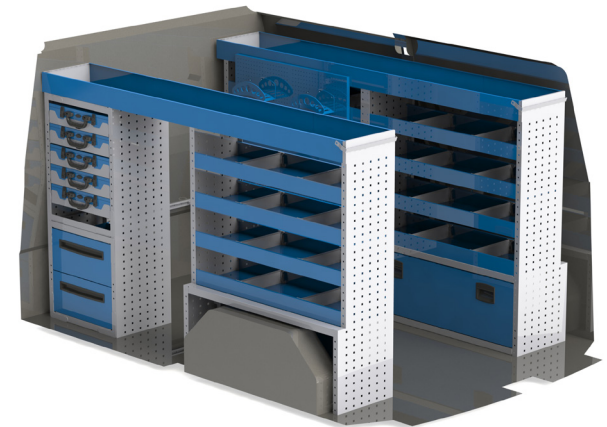

## Plumber

SV-PLUMB



Modular Syncro System Open shelves, Drawers & 5 Pull-out tool cases, Overwheel arch storage doors, Top extendable open trays, Grip plywood linings, LED interior lighting

- ✔ Efficient workspace
- ✔ Commercial grade
- ✔ Maximised storage
- ✔ Safe storage

<b>Weight</b>	197kg
<b>Load Capacity</b>	903kg
<b>Composition</b>	60% Steel, 20% Alloy, 20% Grip ply

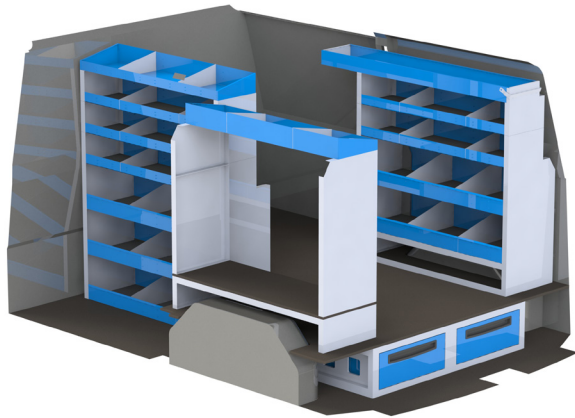

## Service Mechanic

SV-SERVICE



Modular Syncro System open shelves, Underfloor drawers, Grip plywood linings, LED interior lighting

- ✔ Place for every part/tool
- ✔ Ergonomic work zone
- ✔ Light weight
- ✔ Safe workspace

<b>Weight</b>	185kg
<b>Load Capacity</b>	915kg
<b>Composition</b>	60% Steel, 20% Alloy, 20% Grip ply

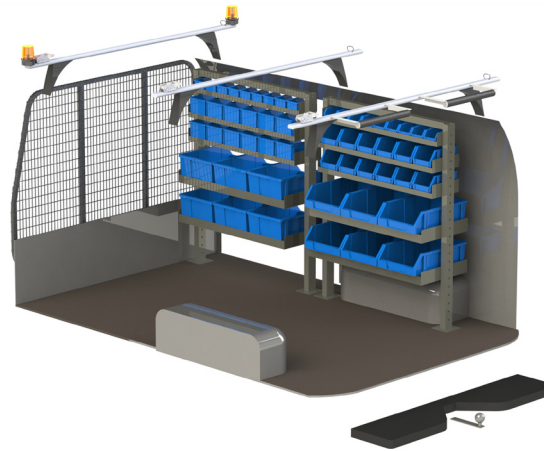

## Tradesman

SV-TRADE



2 x TS150 5 tier shelving kit, Grip plywood linings, Roof rack with tie-down accessories & ladder rollers, LED warning beacons, LED interior lighting, Rear step & towbar

- ✔ Great storage access
- ✔ Safe storage
- ✔ Maximised capacity
- ✔ Economically practical

<b>Weight</b>	190kg
<b>Load Capacity</b>	910kg
<b>Composition</b>	70% Steel, 10% Alloy, 20% Grip ply

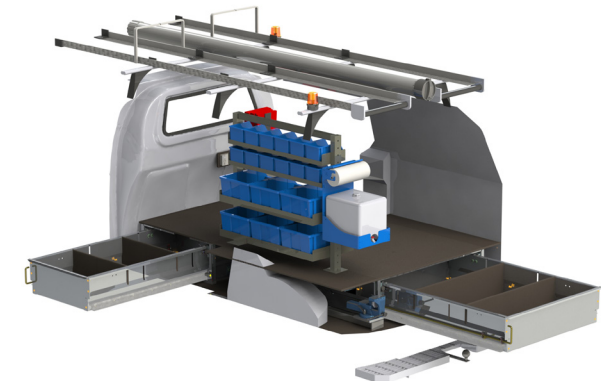

## Electrical Fitter Pro

SV-ELECFIP



TS150 shelving rear, Front dual directional AT drawer & rear drawer, Grip plywood linings, Vice & slide unit, Roof racks with dual extension ladder racks, 3m x 100mm conduit pipe, Power & hygiene kit, LED interior light, warning beacons, Rear step & towbar

- ✔ Easy efficient access
- ✔ Place for every part/tool
- ✔ Ergonomic work zone
- ✔ Commercial grade

<b>Weight</b>	250kg
<b>Load Capacity</b>	850kg
<b>Composition</b>	50% Steel, 20% Alloy, 30% Grip ply

# Large Van Fitouts

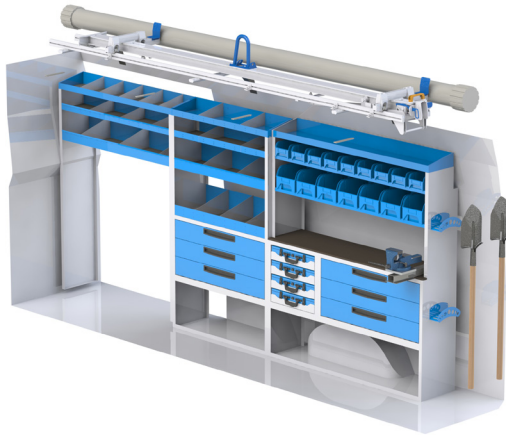

## Cable Joiner 1

LV-CABLEJ1



Modular Syncro System open shelves & bins, drawers & 10 pull-out tool cases, Overwheel arch storage doors, Top extendable open trays, Grip plywood linings, Lockable cupboard, Workbench with vice & slide, Rear door storage, LED interior lighting, 3000W inverter with secondary battery, External warning beacons, Hydraulic assist ladder storage

- ✔ Maximised capacity
- ✔ Efficient workspace
- ✔ Safe workspace
- ✔ Durable

<b>Weight</b>	608kg
<b>Load Capacity</b>	1260kg
<b>Composition</b>	60% Steel, 15% Alloy, 15% Grip ply



## Cable Joiner 2

LV-CABLEJ2



Modular Syncro System open shelves, drawers, Overwheel arch storage doors, Top extenable open trays, Grip plywood linings, Lockable cupboard, Vented gas bottle storage, Workbench, LED interior lighting, 3000W inverter with secondary battery, External warning beacons

- ✔ Ergonomic work zone
- ✔ Easy efficient access
- ✔ Safe workspace
- ✔ Safe storage

<b>Weight</b>	493kg
<b>Load Capacity</b>	1375kg
<b>Composition</b>	60% Steel, 15% Alloy, 15% Grip ply



## Cable Joiner 3

LV-CABLEJ3



Modular Syncro System open shelves and Bins, drawers, Overwheel arch storage doors, Top extendable open trays, Workbench with vice & slide, Grip plywood linings, 3000W inverter with secondary battery, LED interior lighting

- ✔ Place for every cable joiner's part & tool
- ✔ Durable
- ✔ Ergonomic work zone
- ✔ Maximised access

<b>Weight</b>	375kg
<b>Load Capacity</b>	879kg
<b>Composition</b>	60% Steel, 15% Alloy, 15% Grip ply

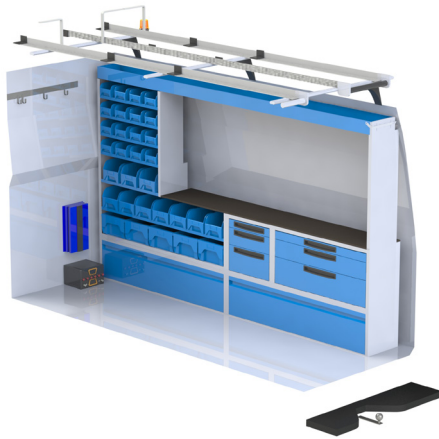

## Electrical Switcher

LV-ELECS



Modular Syncro System open shelves & bins, drawers, Overwheel arch storage doors, Top extendable open trays, Workbench with vice & slide, Grip plywood linings, 3000W inverter with secondary battery, LED interior lighting, Warning beacons, Ladder racks, Rear step & towbar

- ✓ Efficient workspace
- ✓ Safe workspace
- ✓ Durable
- ✓ Safe storage

<b>Weight</b>	450kg
<b>Load Capacity</b>	804kg
<b>Composition</b>	60% Steel, 15% Alloy, 15% Grip ply

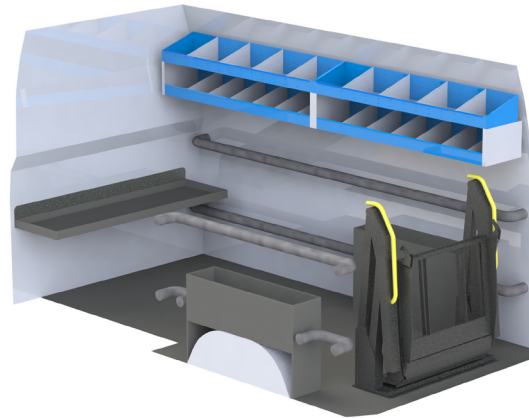

## Machine Service Tech

LV-MACHST



Modular Syncro System open shelves, Side tie rail system, Floor tracking rails with adjustable anchor points, Front fold down shelf, Rear 300kg capacity goods hoist, LED interior lighting, Warning beacons

- ✓ Great bulky storage access
- ✓ Safe storage
- ✓ Maximised capacity
- ✓ Maximised access

<b>Weight</b>	168kg
<b>Load Capacity</b>	1162kg
<b>Composition</b>	40% Steel, 45% Alloy, 15% Grip ply

# Truck Body Fitouts

## What are the key benefits of a Truck Body?



### Unmatched sustainability

Auto Transform aluminium trays and service bodies are 40% lighter than other truck body fitouts, which decreases fuel consumption and gives greater range. Given the durability of the design, they are built to last 2 fitout cycles / 10 years minimum.



### The most functionality

With our range of products, we maximise your productivity by a minimum of 10% in a day, thanks to the large range of standardised modules that are all compatible with each other.



### Increased payload in a Class 1

Auto Transform Aluminium Truck Bodies are unmatched when it comes to maximising your payload capacity on a class 1 license. Proven to be at least 40% lighter than other Truck Body fit-outs, you can be sure you'll be able to carry all the tools you need to be highly efficient in a day and incorporate our compatible storage modules without tapping out your weight limit.



### Increased safety

Our deck mounts and hardware have been crash tested to ensure the durability of these tools of trade, and increased safety for drivers and tools.



### Better return on investment

Durable, modular units can be used for at least two vehicle lives (average 4 years), and can be swapped out at minimum cost if vehicle requirements change.



**“The design was on point and more than fit for purpose, quality of build and products used were very good as well.”**

Unison Contracting Services

# Truck Body Fitouts

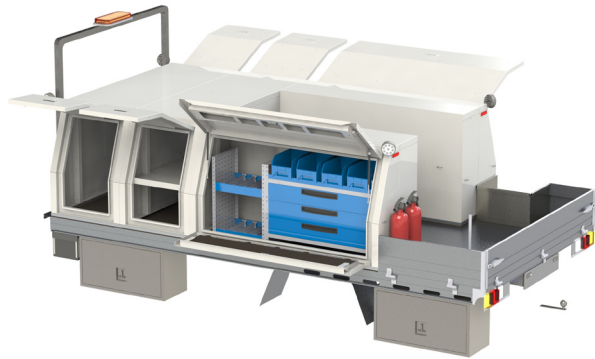

## Electrical Connections

TSB-ELECT



Heavy duty aluminium deck, 2 x 700mm wide gullwing service boxes, 2 x toolbox service bodies (one with split door), Modular Syncro drawers, Open shelving & bins, Integrated wacker mount, 3 x large underdeck boxes, LED warning lights, Underdeck lockable box

- ✓ Place for every part
- ✓ Ergonomic work zone
- ✓ Highly functional workspace
- ✓ Commercial grade & lightweight

<b>Weight</b>	979kg
<b>Load Capacity</b>	2386kg
<b>Composition</b>	30% Steel, 60% Alloy, 10% Grip ply

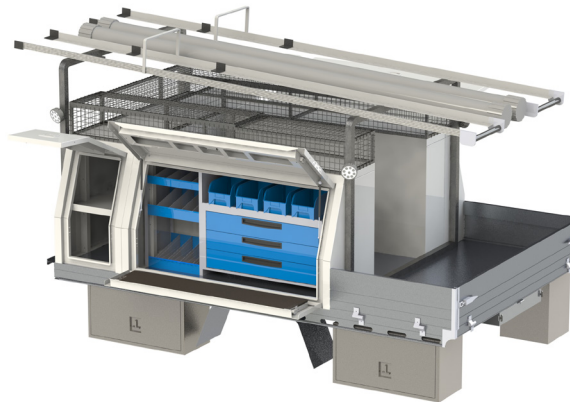

## Linesman

TSB-LINES



Heavy duty aluminium deck, 700mm wide gullwing service box, 2 toolbox service bodies (one with split door), Modular Syncro drawers, Open shelving & bins, 3 large underdeck boxes, LED warning lights, Battery + 2000W inverter kit, Flood lighting, Extension ladder racks with cage storage, Underdeck lockable box, Slide out step

- ✓ Modular storage
- ✓ Segregated safe workspace
- ✓ Efficient workspace
- ✓ Durable & lightweight

<b>Weight</b>	827kg
<b>Load Capacity</b>	2538kg
<b>Composition</b>	30% Steel, 60% Alloy, 10% Grip ply

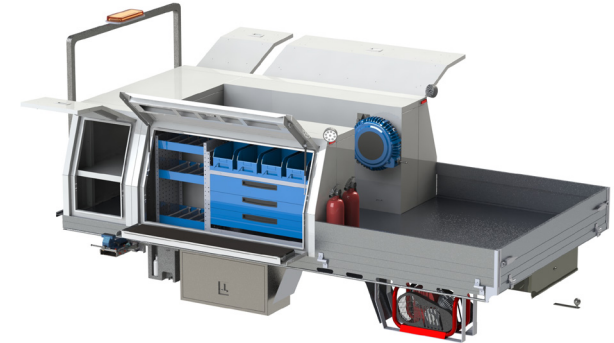

## Mobile Service Tech

TSB-SERVICE



Heavy duty aluminium deck, 1 x 700mm wide gullwing service box, 2 x toolbox service bodies (one with split door), Modular Syncro drawers, Open shelving & bins, 2 x large underdeck boxes, LED warning lights, Battery & 2000W inverter kit, Flood lighting, Underdeck lockable box, Slide out step, Fold out vice, PAB16 compressor

- ✓ Place for every part
- ✓ Ergonomic & safe
- ✓ Maximised efficiency
- ✓ Commercial grade

<b>Weight</b>	861kg
<b>Load Capacity</b>	2504kg
<b>Composition</b>	30% Steel, 60% Alloy, 10% Grip ply

# Truck Body Fitouts



## Plumber

TSB-PLUMB



Heavy duty aluminium deck, 2 x toolbox service bodies one with split door, 3 x H-racks with fold-down pins, slide out step

- ✔ Great bulky storage access
- ✔ Safe storage
- ✔ Maximised capacity
- ✔ Economically practical

<b>Weight</b>	503kg
<b>Load Capacity</b>	2862kg
<b>Composition</b>	30% Steel, 60% Alloy, 10% Grip ply



## Utilities Tech

TSB-UTILITIES



Heavy duty aluminium deck with rear 3 way tipper, 1 x 1200mm wide service box with roller doors, Fixed centre shelf, 2 x underdeck boxes, LED warning lights, Battery and 2000W inverter kit, Flood lighting, 3 x H-racks, 15L water container with soap

- ✔ Ergonomically safe workzone
- ✔ Place for every part
- ✔ Highly functional workspace
- ✔ Durable & lightweight

<b>Weight</b>	988kg
<b>Load Capacity</b>	2377kg
<b>Composition</b>	30% Steel, 60% Alloy, 10% Grip ply



# 3 Way Tipper

**Our easy to operate 3-way tipper is durable, reliable and long lasting.**

The 3-way tipper system maximises your safety while on the job as well as efficiency. You no longer have to back in with your nose in the middle of the road, simply arrange the tray to be tipped which ever side is required, and your operator and operating area is safer and immediately 50% more efficient.



## The most functionality

Three times more functionality than a standard tipper unit. Built to a standard specification and all electronics are plug and play.



## Increased safety

Remove the risk of accident with your vehicle not needing to reverse into an area and block the road.



## Great quality

High-quality crash tested modules and well-segregated drawer systems ensure increased safety for drivers and their tools.



## Better return on investment

You will be around 50% more efficient with the 3 Way Tipper System than a standard conventional tipper. The 3 Way tipper unit is only around 10% more than a standard rear tipper and dependent on the use you will see the returns through time saving at least twice as quick.

# 3 Way Tippers



## Truck Tipper

P/N: #3-WAY-TT

**Dimensions** Up to 4.3m long, 2.1m wide

**Weight** Up to 485kg

Up to 5.5T GVM, 2.5mm steel floor, 45° tipping



## Ute Tipper

P/N: #3-WAY-UT

**Dimensions** Up to 2.5m long, up to 1.8m wide

**Weight** Extra cab 365kg, Single cab 405kg

Up to 3.5 GVM, 2.5mm steel floor, 45° tipping



# Aluminium Flat Deck Trays

**Increase your payload and working functionality without minimising your strength.**



## Unmatched sustainability

Due to the design, all Auto Transform Aluminium Trays are universal mounting which means you can utilize them for at least 2 standard vehicle life cycles thanks to their heavy duty, commercial grade strength. Also, as they are light weight this decreases fuel consumption and gives greater range.



## Increased payload

Auto Transform Aluminium trays are unmatched when it comes to maximising your payload capacity. Proven to be at least 40% lighter than other Aluminium decks, you can be sure you'll be able to carry all the tools you need to be highly efficient in a day and incorporate our compatible storage modules without tapping out your weight limit.



## Increased safety

Our deck mounts and hardware have been crash tested to ensure the durability of these tools of trade, and increased safety for drivers and tools.



## Better return on investment

Durable, transferable Aluminium tray units can be used for at least two vehicle lives (average 4 years), and can be swapped out at minimum cost if vehicle requirements change.



## Highly compatible

Our Aluminium trays are fully compatible with all our Service Body, Syncro System, and Underdeck modules to ensure you maximise your vehicles full potential.

# Flat Decks



## Double Cab Aluminium Flat Deck

P/N: #FLDK-DC

**Dimensions** 1870W x 1800L x 225H

**Weight** 70kg



## Extra Cab Aluminium Flat Deck

P/N: #FLDK-EC

**Dimensions** 1870W x 2100L x 225H

**Weight** 75kg



## Single Cab Aluminium Flat Deck

P/N: #FLDK-SC

**Dimensions** 1870W x 2550L x 225H

**Weight** 85kg



## H-Rack Rear Removable

P/N: #FLDK-HRACK

**Dimensions** 1870W x 60D x 935H

**Weight** 8kg



## Recessed Deck Tie-Downs

P/N: #R-TIEDOWN

**Dimensions** 95W x 100L x 20H

**Weight** 1kg

Zinc-plated steel, 500kg load rating

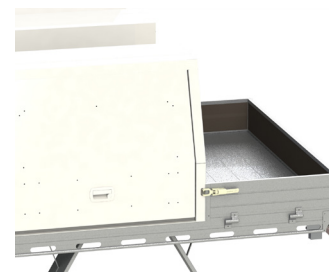

## Grip Ply & Tailgate Inserts

P/N: #PLYINS-18MM

**Dimensions** Deck size dependent

**Weight** 5kg

18mm grip ply sides & tailgate inserts on flat deck

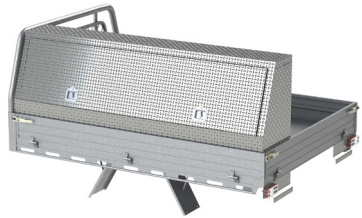

### Full Width Tool Box

P/N: #TB-FW

**Dimensions** 1750W x 500L x 500H

**Weight** 18kg

Checker plate alloy 2.5mm



### Full Length Tool Box

P/N: #TB-FL

**Dimensions** 500W x 2200L x 850H

**Weight** 8kg

Checker plate alloy 2.5mm



### Standard Rear Tipper Ute

P/N: #UTE-REAR-TIPPER

**Dimensions** Deck size dependent

**Weight** 65kg

Compatible with double, extra & single cab decks.

# Canopies



## Canopy Dynamic Pro DC

P/N: #TRITONDPCNPY

**Dimensions** Suited to vehicle specific wellside

**Weight** 60kg

Fits Mitsubishi Triton Double Cab



## Canopy Dynamic Pro EC

P/N: #RANGERDPCNPYEC

**Dimensions** Suited to vehicle specific wellside

**Weight** 80kg

Fits Ford Ranger Extra Cab



## Canopy Dynamic Pro SC

P/N: #TRITONDPCNPY

**Dimensions** Suited to vehicle specific wellside

**Weight** TBC

Fits Mitsubishi Triton Super Cab



## Plastic Deck Liner

P/N: #LINER-D/C-UR

**Dimensions** Suited to vehicle specific wellside

**Weight** 15kg

Available for Ranger, Triton and Hilux

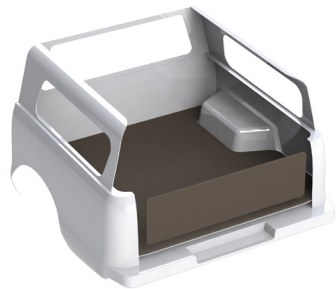

## Grip Plywood Decking & Tailgate

P/N: #LINER-12MMGRIP-D/C

**Dimensions** Model Dependent

**Weight** 20kg

12mm



## Front Window Mesh Barrier

P/N: #WB-CANOPY

**Dimensions** Universal fitment for AT Canopies

**Weight** 3kg

# Service Bodies



## Split DC Service Body

P/N: #SB-DC-SPD

**Dimensions** 1870W x 1720L x 930H

**Weight** 160kg

Split door LH & RH & rear door



## Gull DC Service Body

P/N: #SB-DC-GWD

**Dimensions** 1870W x 1720L x 930H

**Weight** 152kg

Gull door LH & RH & rear door



## Split EC Service Body

P/N: #SB-EC-SPD

**Dimensions** 1870W x 2100L x 930H

**Weight** 183kg

Split door LH & RH & rear door

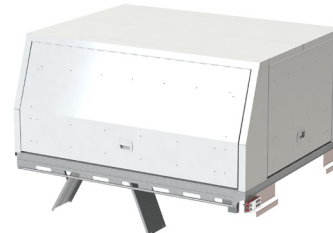

## Gull EC Service Body

P/N: #SB-EC-GWD

**Dimensions** 1870W x 2100L x 930H

**Weight** 178kg

Gull door LH & RH & rear door

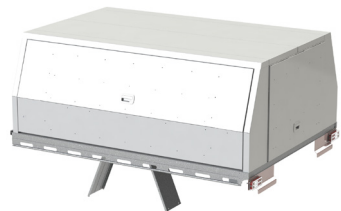

## Split SC Service Body

P/N: #SB-SC-SPD

**Dimensions** 1870W x 2550L x 930H

**Weight** 205kg

Split door LH & RH & rear door



## Gull SC Service Body

P/N: #SB-SC-GWD

**Dimensions** 1870W x 2550L x 930H

**Weight** 195kg

Gull door LH & RH & rear door

# Service Bodies



## Short Gull Service Body

P/N: #SBTB1250

**Dimensions** 650W x 1250L x 930H

**Weight** 45kg

1250 long with gullwing door

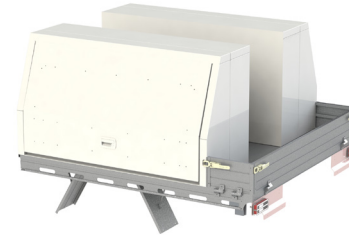

## Long Gull Service Body

P/N: #SBTB-GWD1720

**Dimensions** 650W x 1720L x 930H

**Weight** 55kg

1720 long with gullwing door



## Split Door Service Body

P/N: #SBTB-SPD1720

**Dimensions** 650W x 1720L x 930H

**Weight** 59kg

1720 long with split door



# Truck Flat Decks



## Truck Deck Small

P/N: #TKDK3000

**Dimensions** 1800W x 3000L x 323H

**Weight** 212kg



## Truck Deck Large

P/N: #TKDK4500

**Dimensions** 2122W x 4500L x 323H

**Weight** 242kg



## Rear H-Rack

P/N: #TKH-RACK

**Dimensions** Made to suit specification

**Weight** 30kg



## Foliage Grid & Tailgate Extension

P/N: #TKDK-FOL

**Dimensions** Made to suit specification

**Weight** 144kg

# Truck Service Bodies



## Split Door Tool Box Small

P/N: #SBTB-SPD1720

**Dimensions** 650W x 1720L x 930H

**Weight** 85kg



## Gull Door Tool Box Small

P/N: #SBTB-GWD1720

**Dimensions** 650W x 1720L x 930H

**Weight** 85kg



## Split Door Service Body Medium

P/N: #TSB-1720-GWD

**Dimensions** 2000W x 1720L x 930H

**Weight** 125kg



## Gull Door Service Body Medium

P/N: #TSB-1720-SPD

**Dimensions** 2000W x 1720L x 930H

**Weight** 125kg



## Split Door Service Body Large

P/N: #TSB-2500-SPD

**Dimensions** 2000W x 2550L x 930H

**Weight** 140kg



## Gull Door Service Body Large

P/N: #TSB-2500-GWD

**Dimensions** 2000W x 2550L x 930H

**Weight** 140kg



### Gull Door Service Body Narrow

P/N: #TSB-700-GWD

**Dimensions** 2100W x 600L x 930H

**Weight** 115kg



### Underdeck Tool Box Small

P/N: #TTB-UD-SML

**Dimensions** 400W x 500W x 350H

**Weight** 15kg



### Underdeck Tool Box Large

P/N: #TTB-UD-LRG

**Dimensions** 800W x 500W x 500H

**Weight** 27kg

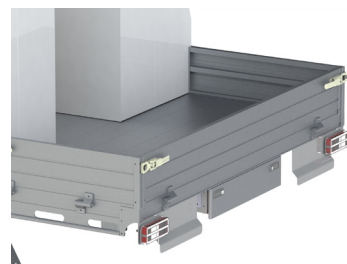

### Underdeck Long Storage Box

P/N: #UDD-2100

**Dimensions** 870W x 2100L x 120H

**Weight** 45kg



### Underdeck Slide Out Step

P/N: #STP-UD-LRG

**Weight** 12kg

# Syncro System for Professionals

**Imagine having limitless possibilities for building a customised solution to transform your workspace.**

To be able to achieve such flexibility lies in the key word: Modularity. Making customised fit-outs standardised, we go modular. Here's why this can benefit you and your fleet.

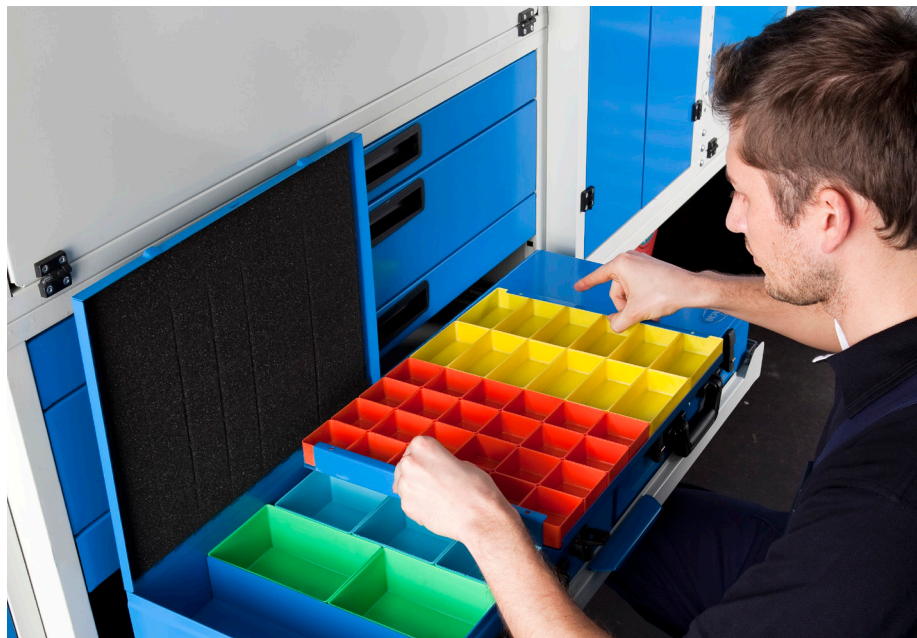

## Unmatched space

Various sizes and configurations allow you to stow all your tools safely and tidily while leaving plenty of space for transporting cargo.



## Light weight

With cut-through design technology Syncro system is 30% lighter than traditional shelving enabling you to carry all your tools and parts without exceeding any payload limits.



## Increased safety

High-quality crash tested modules and well-segregated drawer systems ensure increased safety for drivers and their tools.



## Maximum productivity

Professional storage system ensures a place for every part, maximising your efficiency and saving you time and money.



## Better return on investment

Durable, transferable modules can be used for at least two vehicle lives (average 4 years), and can be swapped out at minimum cost if vehicle requirements change.



## Highly compatible

Syncro System racking and accessories are compatible with all our products, to ensure you maximise your vehicles full potential for your trade.

# Syncro System Canopy Modules

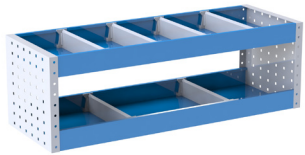

## 2 Tier Shelving Canopy

P/N: #VT20/35-2

**Dimensions** 1000W x 360D x 300H

**Weight** 12kg

2 tier floating open shelving with rubber mat and dividers

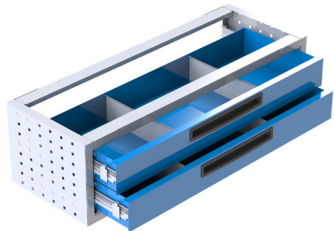

## Double Drawer Canopy

P/N: #F00200/35

**Dimensions** 1000W x 360D x 240H

**Weight** 10kg

Floating drawer system out canopy side opening

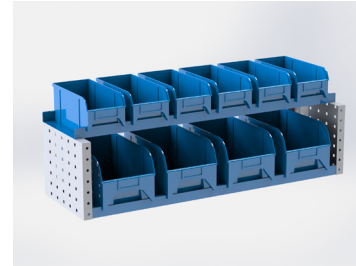

## Bin Shelving Canopy

P/N: #PB20/26-1,31-1

**Dimensions** 1000W, Shelves 260D & 310D

**Weight** 13kg

2 tier floating shelving with bins 260D & 310D out canopy side opening

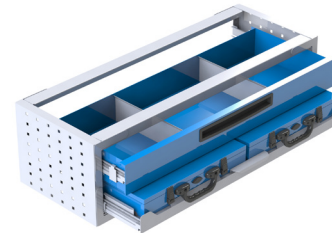

## Single Drawer Canopy

P/N: #F10100/35

**Dimensions** 1000W x 360D x 240H

**Weight** 10kg

Floating with 2 x pull out tool cases out canopy side opening

# Syncro System Bins & Shelving



## Parts Bins 4 Tier 750W

P/N: #PB15/26-3,31-1

**Dimensions** 750W x 310D x 960H

**Weight** 18kg

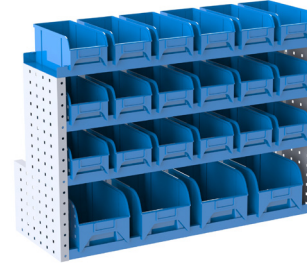

## Parts Bins 4 Tier 1000W

P/N: #PB20/26-3,31-1

**Dimensions** 1000W x 310D x 960H

**Weight** 22kg

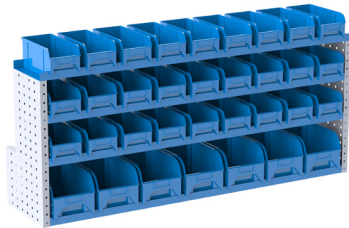

## Parts Bins 4 Tier 1500W

P/N: #PB30/26-3,31-1

**Dimensions** 1500W x 310D x 960H

**Weight** 30kg

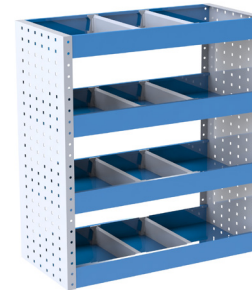

## Open Shelving 4 Tier 750W

P/N: #VT15/35-4

**Dimensions** 750W x 350D x 960H

**Weight** 19kg

With rubber mat and dividers



## Open Shelving 4 Tier 1000W

P/N: #VT20/35-4

**Dimensions** 1000W x 350 x 960H

**Weight** 22kg

With rubber mat and dividers

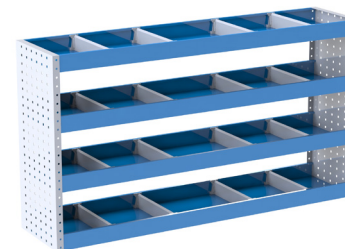

## Open Shelving 4 Tier 1500W

P/N: #VT30/35-4

**Dimensions** 1500W x 350D x 960H

**Weight** 35kg

With rubber mat and dividers

# Syncro System Shelving & Drawers

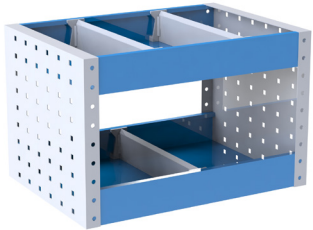

## Open Shelving 2 Tier 500W

P/N: #VT10/35-2

**Dimensions** 500W x 350D x 480H

**Weight** 8kg

With rubber mat and dividers

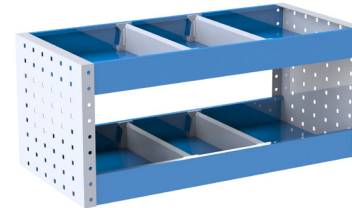

## Open Shelving 2 Tier 750W

P/N: #VT15/35-2

**Dimensions** 750W x 350D x 480H

**Weight** 9kg

With rubber mat and dividers

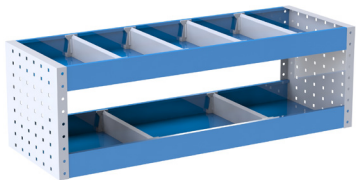

## Open Shelving 2 Tier 1000W

P/N: #VT20/35-2

**Dimensions** 1000W x 350D x 480H

**Weight** 11kg

With rubber mat and dividers

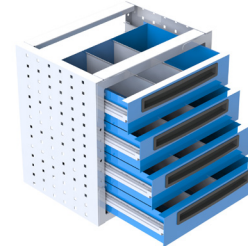

## Drawer Unit 4 x 100H

P/N: #A00400/35

**Dimensions** 507W x 483D x 350H

**Weight** 22kg

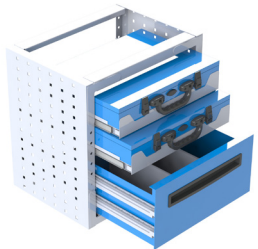

## Drawer with 2 Trays

P/N: #A20001/35

**Dimensions** 507W x 483D x 350H

**Weight** 27kg

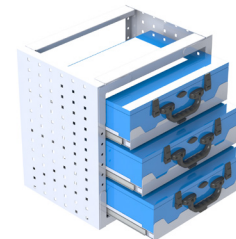

## Drawer with 3 Trays

P/N: #A30000/35

**Dimensions** 507W x 483D x 350H

**Weight** 30kg

# Syncro System Drawers

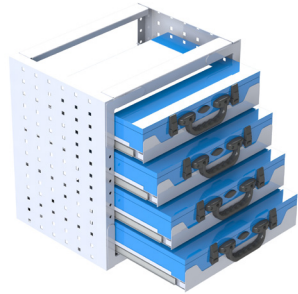

## Drawer with 4 Trays

P/N: #A40000/35

**Dimensions** 507W x 483D x 350H

**Weight** 30kg

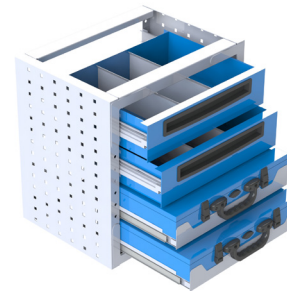

## 2 Drawers & 2 Trays

P/N: #A20200/35

**Dimensions** 507W x 483D x 350H

**Weight** 24kg

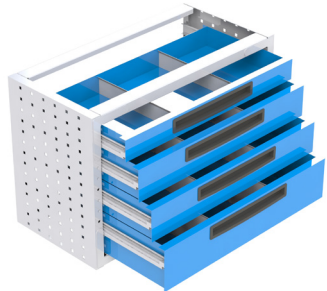

## 4 Drawer Unit

P/N: #B01210/35

**Dimensions** 760W x 483D x 350H

**Weight** 28kg

1 x 55H, 2 x 100H, 1 x 130H

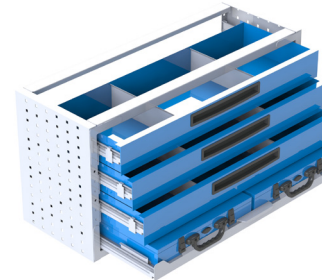

## 3 Drawer Unit with Tool Box Tray

P/N: #C10300/35

**Dimensions** 1014W x 483D x 350H

**Weight** 40kg

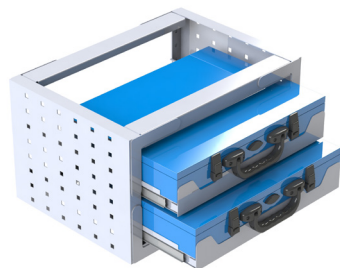

## 1 Drawer Unit with Tool Box Trays

P/N: #D20000/35

**Dimensions** 507W x 241D x 350H

**Weight** 18kg

With 2 trays 2 tool boxes



## Underfloor Drawer Unit 540W

P/N: #STP01/5495

**Dimensions** 540W x 241H x 950D

**Weight** 26kg

With rubber mat and 4 dividers



# Syncro System Drawers

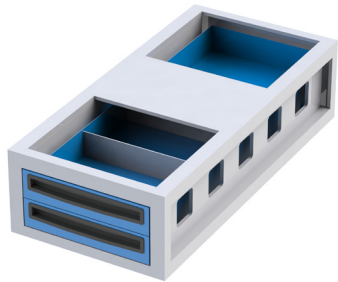

## Double Underfloor Drawers 540W

P/N: #STP20/5495

**Dimensions** 540W x 241H x 950D

**Weight** 35kg

With rubber mat and 4 dividers



## Underfloor Drawers 450W

P/N: #STP01/4595

**Dimensions** 450W x 241H x 950D

**Weight** 24kg

With rubber mat and 4 dividers

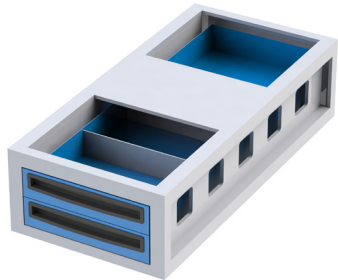

## Double Underfloor Drawers 450W

P/N: #STP20/4595

**Dimensions** 450W x 241H x 950D

**Weight** 32kg

With rubber mat and 4 dividers



## Underfloor Drawers 540W

P/N: #STP01/549550

**Dimensions** 540W x 480H x 950D

**Weight** 37kg

With rubber mat and 4 dividers

# Cupboard Storage Units



## Lockable 4Kg Gas Cabinet

P/N: #GAS4KG

**Dimensions** 320W x 510H x 290D

**Weight** 4.5kg



## Lockable 9Kg Gas Cabinet

P/N: #GAS9KG

**Dimensions** 360W x 530H x 390D

**Weight** 8kg



## Lockable Oxyacetylene Cabinet

P/N: #GAS-OXYA

**Dimensions** 230W x 680H x 430D

**Weight** 6kg



## D-Size Gas Bottle Holder

P/N: #GAS-DSIZE

**Dimensions** 240W x 400H x 200D

**Weight** 5kg

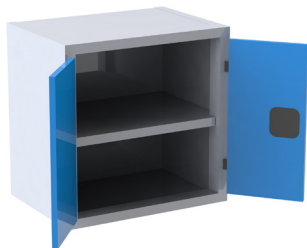

## Lockable Cupboard Unit Small

P/N: #ARM-BOX/4835

**Dimensions** 507H x 483W x 353D

**Weight** 13kg

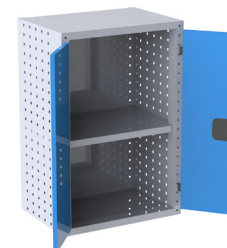

## Lockable Cupboard Unit Medium

P/N: #ARM-BOX/7235

**Dimensions** 507H x 724W x 353D

**Weight** 17kg

# Cupboard Storage Units



## Lockable Cupboard Unit Large

P/N: #ARM-BOX/9635

**Dimensions** 507H x 966W x 353D

**Weight** 22kg



## Lockable Cupboard Unit XL

P/N: #ARM-BOX/12035

**Dimensions** 507H x 1207W x 353D

**Weight** 26kg

# Trade System+ Drawers

## Increase your functionality with the simple versatility of our Trade System.

Auto Transform's Trade System+ Drawer Unit is another breakthrough modular product. This drawer unit really transforms a large cavity of open space like no other.



### Most functional modular drawer system

You can change between having dual direction, single direction, stackable and lockable all in one drawer system. Various standard sizes are made to standard vehicle configurations allow you to stow all your tools safely and tidily while leaving plenty of space for transporting cargo.



### Increased safety

High-quality crash tested modules and well-segregated drawer systems ensure increased safety for drivers and their tools. Every Trade System+ Drawer comes with integrated / interchangeable dividers and drawer lock.



### Light weight

Using marine grade aluminium and steel componentry we have minimised the weight while maximising the durability of this product.



### Better return on investment

Durable, transferable Trade System+ Drawer modules can be used for at least two vehicle lives (average 4 years) and can be swapped out at minimum cost if vehicle requirements change. The best thing is that they can be re-purposed to maximise the utilisation of your asset even if you change from a ute to a van due to its un-matched functionality.



### Flat pack

The trade system+ drawers are the only commercial large drawer that is flat packed, meaning they can be sent anywhere at a minimum cost and easily installed and assembled.

# Large Drawers

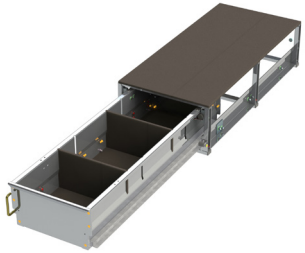

## Small Single Drawer Unit

P/N: #SD05014030

**Dimensions** 500W x 1400D x 300H

**Weight** 15kg

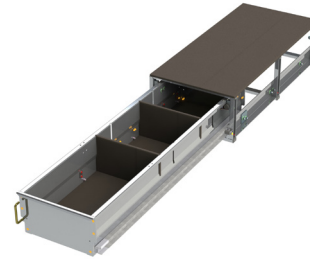

## Medium Single Drawer Unit

P/N: #SD05017030

**Dimensions** 500W x 1700D x 300H

**Weight** 20kg

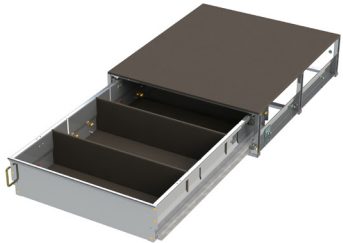

## Large Single Drawer Unit

P/N: #SD10014030

**Dimensions** 1000W x 1400D x 300H

**Weight** 25kg

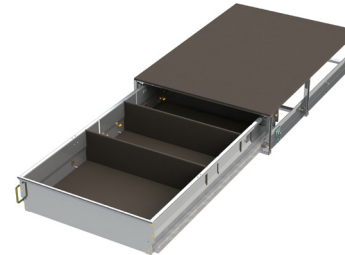

## XL Single Drawer Unit

P/N: #SD10017030

**Dimensions** 1000W x 1700D x 300H

**Weight** 28kg

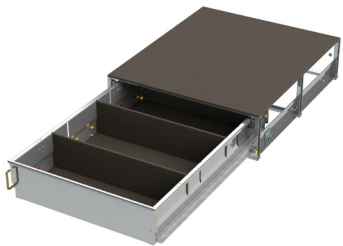

## Dual Way Single Drawer

P/N: #SDDW10014030

**Dimensions** 1000W x 1400D x 300H

**Weight** 25kg

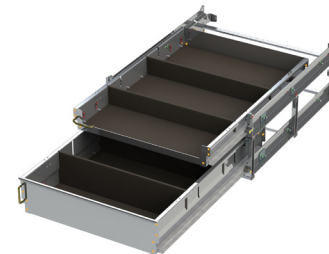

## Double Drawer Unit

P/N: #DD10014040

**Dimensions** 1000W x 1400D x 300H + 100H

**Weight** 38kg

# Large Drawers



## Dual Way Sliding Tray

P/N: #STDW10014010

**Dimensions** 1000W x 1400D x 150H

**Weight** 20kg

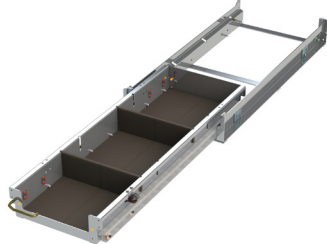

## Small Sliding Tray Unit

P/N: #ST05014010

**Dimensions** 500W x 1400D x 150H

**Weight** 18kg

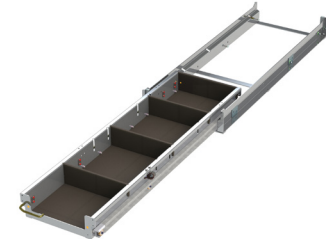

## Medium Sliding Tray Unit

P/N: #ST05017010

**Dimensions** 500W x 1700D x 150H

**Weight** 18kg



## Large Sliding Tray Unit

P/N: #ST10014010

**Dimensions** 1000W x 1400D x 150H

**Weight** 20kg



## XL Sliding Tray Unit

P/N: #ST10017010

**Dimensions** 1000W x 1700D x 150H

**Weight** 25kg

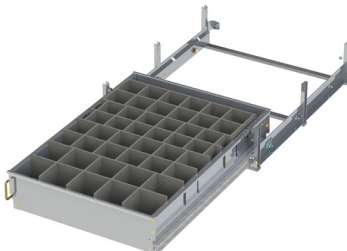

## Fire Extinguisher Drawers

P/N: #FEPLATFORM

**Dimensions** 1000W x 1400D x 300H

**Weight** 65kg

# Trade System Shelving & Accessories

## Economise your workspace with the simple versatility of our Trade System.

Auto Transform's Trade System is a kit-set ready-to-install shelving and bin system that has multiple accessory options to ensure your vehicle functions better as a tool of trade. This is done through better utilisation of your space through simple organisation.

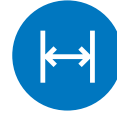

### Increased storage capacity

Various sizes and configurations allow you to stow all your tools safely and tidily while leaving plenty of space for transporting cargo.



### Increased safety

High-quality crash tested modules and well-segregated bin systems ensure increased safety for drivers and their tools.



### Better return on investment

Durable, transferable Trade System units can be used for at least two vehicle lives (average 4 years), and can be swapped out at minimum cost if requirements change.



### Flat pack

The trade system shelving and accessories can be flat packed, meaning they can be sent anywhere at a minimum cost and easily installed and assembled.



### Highly compatible

Trade System racking and accessories are compatible with all our Service Bodies, and Syncro System, to ensure you maximise your vehicles full potential for your trade.

# Trade System Shelving & Accessories

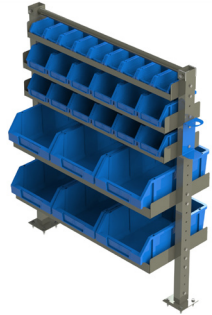

## 5 Tier Unit with 27 Bins

P/N: #TS150F

**Dimensions** 1000W x 1230H x 450D

**Weight** 49kg



## 5 Tier Unit with 54 Bins

P/N: #TS250F

**Dimensions** 2000W x 1230H x 450D

**Weight** 98kg



## 3 Tier Unit with Shelves & Bins

P/N: #TS130FS

**Dimensions** 1000W x 1230H x 450D

**Weight** 40kg

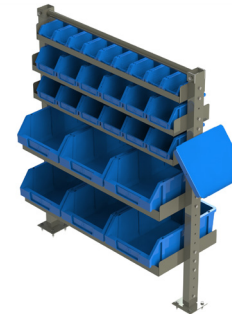

## Laptop/Tablet Mount

P/N: #44004179

**Dimensions** 310W x 250H x 200D

**Weight** 1kg

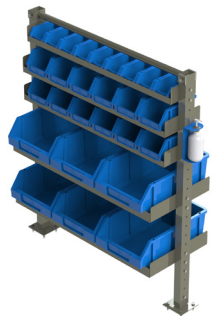

## Hand Sanitiser

P/N: #44004180

**Dimensions** 80W x 150H x 65D

**Weight** 1kg

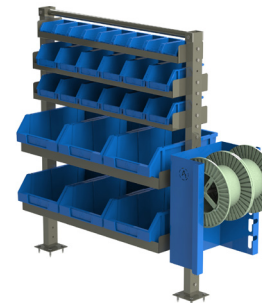

## Cable Roll Holder

P/N: #44004181

**Dimensions** 415W x 500H x 210D

**Weight** 2kg



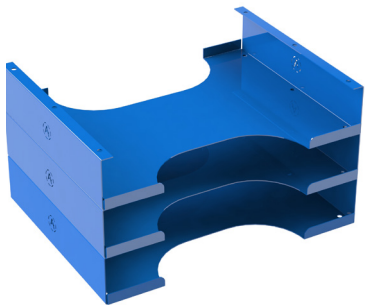

### Parts Bins Holder (Stackable)

P/N: #44004182

**Dimensions** 460W x 85H x 360D each

**Weight** 2kg

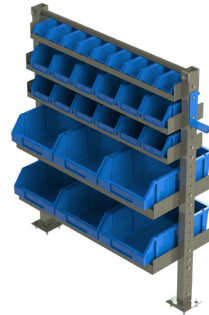

### Extension Lead Hook

P/N: #44004184

**Weight** 0.5kg

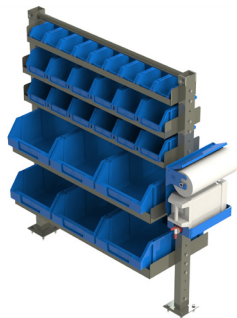

### 5L Water & Paper Towel Holder

P/N: #44004185

**Dimensions** 310W x 330H x 144D

**Weight** 1.5kg

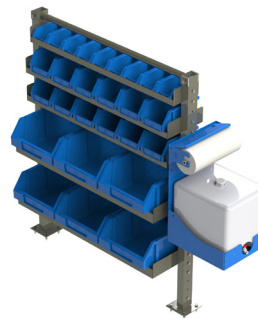

### 20L Water & Paper Towel Holder

P/N: #44004186

**Dimensions** 310W x 510H x 310D

**Weight** 2.5kg

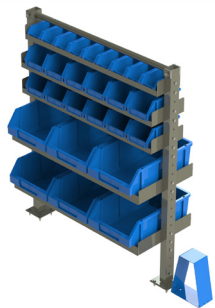

### Cone Holder

P/N: #44004187

**Dimensions** 200W x 250H x 100D

**Weight** 1kg



### Work Bench Kit 750mm

P/N: #MISC

**Dimensions** 750W x 960H x 350D

**Weight** 30kg

# Trade System Shelving & Accessories



## Work Bench Kit 1000mm

P/N: #WBK-1000

**Dimensions** 1000W x 960H x 350D

**Weight** 40kg

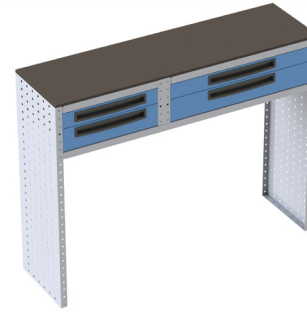

## Work Bench Kit 1250mm

P/N: #WBK-1250

**Dimensions** 1250W x 960H x 350D

**Weight** 50kg

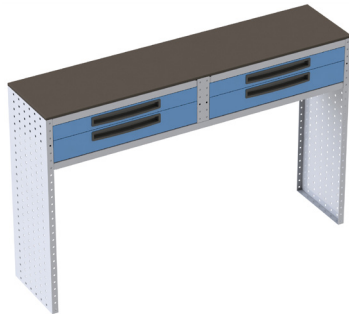

## Work Bench Kit 1500mm

P/N: #WBK-1500

**Dimensions** 1500W x 960H x 350D

**Weight** 60kg

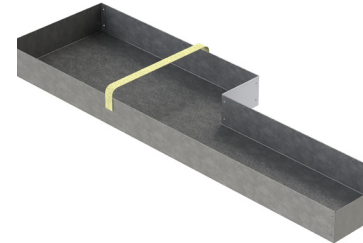

## Shovel Tray

P/N: #SHOVELTRAY

**Weight** 4kg



## Shovel & Broom Hanger

P/N: #40004045

**Weight** 1kg

# Van Linings



## 12mm Grip Ply Floor Small

P/N: #PFPFSWBK

**Dimensions** Vehicle Specific

**Weight** 12kg

Suitable for a small van

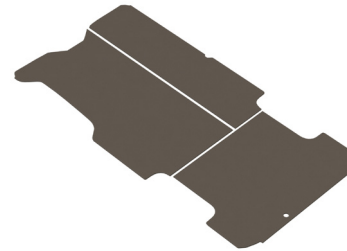

## 12mm Grip Ply Floor Large

P/N: #PFPFLWBK

**Dimensions** Vehicle Specific

**Weight** 20kg

Suitable for a large van



## 12mm Standard Ply Floor Small

P/N: #PLYFLSWBVK

**Dimensions** Vehicle Specific

**Weight** 12kg

Suitable for a small van



## 12mm Standard Ply Floor Large

P/N: #PLYFLLWBVK

**Dimensions** Vehicle Specific

**Weight** 12kg

Suitable for a large van

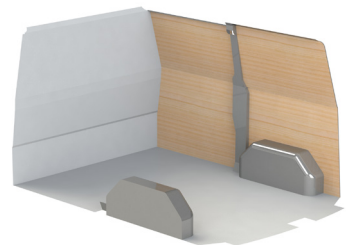

## 7mm Ply Full Sides Small

P/N: #PLYSFHSSWBVK

**Dimensions** Vehicle Specific

**Weight** 15kg

Suitable for a small van



## 7mm Ply Full Sides Large

P/N: #PLYSFHLLWBVK

**Dimensions** Vehicle Specific

**Weight** 6kg

Suitable for a large van

# Van Linings

---



## 5mm Rubber Mat Small

P/N: #RUBFLSWBVK

---

**Dimensions** Vehicle Specific

---

**Weight** 5kg

---

Suitable for a small van

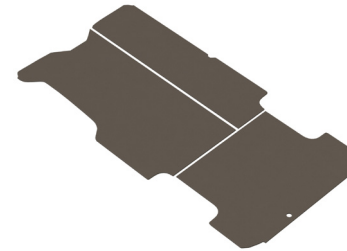

## 5mm Rubber Mat Large

P/N: #RUBFLLWBVK

---

**Dimensions** Vehicle Specific

---

**Weight** 8kg

---

Suitable for a large van

# Underdeck Accessories

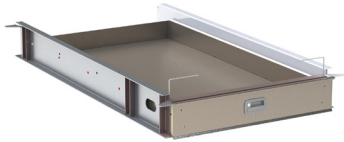

## Underdeck Drawer Double Cab

P/N: #UDD-1500

**Dimensions** 870W x 1500L x 120H

**Weight** 60kg

100kg capacity

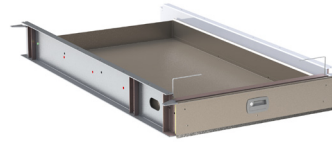

## Underdeck Drawer Extra Cab

P/N: #UDD-1800

**Dimensions** 870W x 1800L x 120H

**Weight** 70kg

100kg capacity

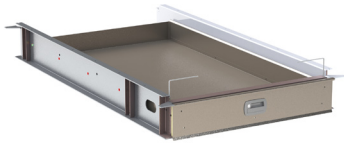

## Underdeck Drawer Single Cab

P/N: #UDD-2100

**Dimensions** 870W x 2100L x 120H

**Weight** 80kg

100kg capacity

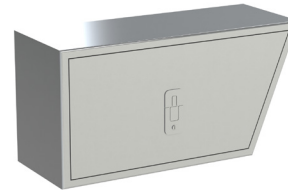

## Underdeck Box Rear RHS

P/N: #TB-UD-RRH

**Dimensions** 260W x 600L X 400H

**Weight** 3kg

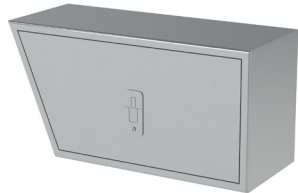

## Underdeck Box Rear LHS

P/N: #TB-UD-RLH

**Dimensions** 260W x 600L X 400H

**Weight** 3kg



## Underdeck Box Front RHS

P/N: #TB-UD-SFRH

**Dimensions** 240W x 300L X 400H

**Weight** 2kg

# Underdeck Accessories



## Underdeck Box Front LHS

P/N: #TB-UD-SFLH

**Dimensions** 240W x 300L X 400H

**Weight** 2kg



## 15L Water Container

P/N: #15LWATERUD

**Dimensions** 250W x 340L x 310H

**Weight** 3kg

Plastic container with tap and soap dispenser



## Underdeck Sidestep Small

P/N: #STP-UD-SML

**Weight** 1kg



## Underdeck Sidestep Large

P/N: #STP-UD-LRG

**Weight** 2kg

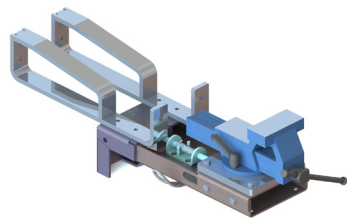

## Underdeck Fold Out Vice

P/N: #VICE110.FOLDK

**Dimensions** 110mm

**Weight** 12kg

With swivel base



## Electrical Roll Holder

P/N: #E-ROLL-UD

**Dimensions** 950mm wide

**Weight** 3kg



### Underdeck Battery & Step Mount

P/N: #UDBM

---

**Weight** 4kg

---



### Underdeck 4kg Gas Cabinet LHS

P/N: #GAS4KGUD

---

**Dimensions** To suit 4kg gas bottle

---

**Weight** 4kg

---

# Roof Racks & Accessories

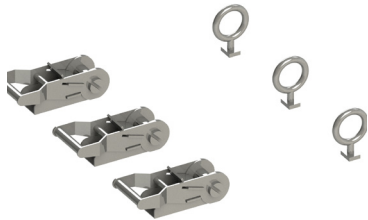

## Ratchets and Eyebolts

P/N: #RR-EYEBOLT/RATCHET

**Weight** 1kg

3 Pairs



## Safe Clamp

P/N: #40009042

**Dimensions**

**Weight** 2.5kg

1 Pair



## Rear Roller

P/N: #RR-ROLLER525

**Dimensions** 525 wide

**Weight** 2kg

525mm



## Load Holders

P/N: #40003072

**Dimensions** 150mm high

**Weight** 1.5kg

1 Pair, 150mm High



## 100mm Conduit Pipe 2M

P/N: #100COND2MTR

**Dimensions** 2000mm L x 100m H

**Weight** 4kg

With push-on cap & end locking cap



## 100mm Conduit Pipe 3M

P/N: #100COND3MTR

**Dimensions** 3000mm L x 100m H

**Weight** 4.5kg

With push-on cap & end locking cap





### 100mm Conduit Pipe 4M

P/N: #100COND4MTR

**Dimensions** 4000mm L x 100m H

**Weight** 5kg

With push-on cap & end locking cap



### 150mm Conduit Pipe 2M

P/N: #150COND2MTR

**Dimensions** 2000mm L x 150m H

**Weight** 5kg

With push-on cap & screw cap



### 150mm Conduit Pipe 3M

P/N: #150COND3MTR

**Dimensions** 3000mm L x 150m H

**Weight** 5kg

With push-on cap & screw cap



### 150mm Conduit Pipe 4M

P/N: #150COND4MTR

**Dimensions** 4000mm L x 150m H

**Weight** 6kg

With push-on cap & screw cap



### DC Service Body Roof Rack

P/N: #RR3BARSB

**Dimensions** 1300 wide bars

**Weight** 4kg



### EC Service Body Roof Rack

P/N: #RR3BARSB

**Dimensions** 1300 wide bars

**Weight** 4kg

# Roof Racks & Accessories



## Extension Ladder Sliding Rail

P/N: #EXTLADDER

**Dimensions** 3000L x 500W x 100H

**Weight** 12kg



## Step Ladder Sliding Rail

P/N: #STPLADDER

**Dimensions** 2600L x 350-650W x 100H

**Weight** 10kg



## Extension Ladder Lock Left

P/N: #EXT-LADDER-LOCK-LH

**Weight** 12kg



## Extension Ladder Lock Right

P/N: #EXT-LADDER-LOCK-RH

**Weight** 12kg

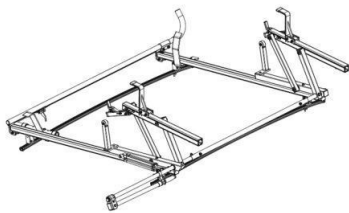

## Ergo Rack

P/N: #MISC

**Dimensions** to suit vehicle model

**Weight** 28kg

Side loading

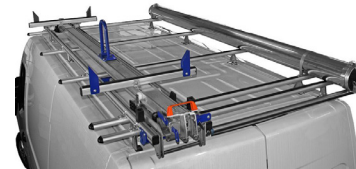

## Slide-Out for Ladder Rack

P/N: #SRM27

**Dimensions** 500W x 150H x 2700L

**Weight** 25kg

Hydraulic assisted unloading with ladder retainer, unblocking rod, support legs and straps



### Jet Rack Step Ladder Holder

P/N: #JETRACK

**Dimensions** 150W x 150H x 1600L

**Weight** 5kg

Internally roof mounted



### 3 Bar Roof Rack Gutter Mount

P/N: #RR3BARHIACEZX

**Dimensions** 1500 or 1300 wide bars

**Weight** 5kg

Fits Toyota Hiace ZX or ZR



### iLoad / T5 3 Bar Roof Rack

P/N: #RR3BARILOADT5

**Dimensions** 1500 or 1300 wide bars

**Weight** 10kg

Fits Hyundai iLoad or VW T5



### Cantilever Rack Long

P/N: #CANT2.5

**Dimensions** 1100W x 100H x 2500L

**Weight** 6.5kg

With tie rails



### Cantilever Rack Short

P/N: #CANT1.5

**Dimensions** 1100W x 100H x 1500L

**Weight** 5.5kg

With tie rails

# Glass Transport



### External Glass Frail System

P/N: #GF3022

**Dimensions** 300W x 2200H x 3000L

**Weight** 60kg

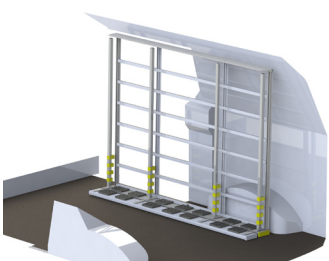

### Internal Glass Frail System

P/N: #GF1620I

**Dimensions** 300W x 1250H x 2000L

**Weight** 40kg



### Internal Windscreen Storage

P/N: #TKH-RACK

**Dimensions** 750W x 1200H x 1400L

**Weight** 18kg

Fits 8 screens, for a large van

# Safety Barriers



## Bulkhead Small Front Mount

VEHICLE SPECIFIC

**Dimensions** Vehicle Specific

**Weight** 12kg

Fibreglass composition



## Bulkhead Small Mid Mount

VEHICLE SPECIFIC

**Dimensions** Vehicle Specific

**Weight** 12kg

Fibreglass composition

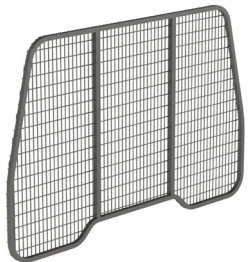

## Mesh Barrier Small Front Mount

VEHICLE SPECIFIC

**Dimensions** Vehicle Specific

**Weight** 20kg

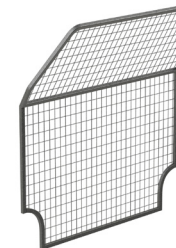

## Mesh Barrier Small Mid Mount

VEHICLE SPECIFIC

**Dimensions** Vehicle Specific

**Weight** 20kg



## Bulkhead Large Front Mount

VEHICLE SPECIFIC

**Dimensions** Vehicle Specific

**Weight** 25kg

Fibreglass composition



## Bulkhead Large Mid Mount

VEHICLE SPECIFIC

**Dimensions** Vehicle Specific

**Weight** 25kg

Fibreglass composition

# Safety Barriers

---

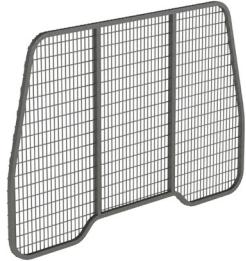

## Mesh Barrier Large Front Mount

VEHICLE SPECIFIC

**Dimensions** Vehicle Specific

**Weight** 25kg

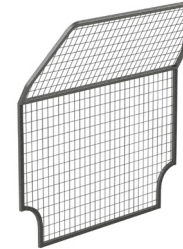

## Mesh Barrier Large Mid Mount

VEHICLE SPECIFIC

**Dimensions** Vehicle Specific

**Weight** 25kg

# External Accessories



## Towbar & Wiring R178

P/N: #TOWBAR&WIRING

**Dimensions** Vehicle Specific

**Weight** 25kg

Removable tongue, 1-7/8ths towball



## Towbar & Wiring F178

P/N: #TOWBAR&WIRING

**Dimensions** Vehicle Specific

**Weight** 25kg

Fixed tongue, 1-7/8ths towball



## Towbar & Wiring R50

P/N: #TOWBAR&WIRING

**Dimensions** Vehicle Specific

**Weight** 25kg

Removable tongue, 50mm towball



## Towbar & Wiring F50

P/N: #TOWBAR&WIRING

**Dimensions** Vehicle Specific

**Weight** 25kg

Fixed tongue, 50mm towball



## Towbar & Wiring LT400

P/N: #TOWBAR&WIRING

**Dimensions** Vehicle Specific

**Weight** 25kg

Fixed tongue, LT400 certification



## Integrated Step with Sensors

P/N: #TOWBAR&WIRING

**Dimensions** Vehicle Specific

**Weight** 40kg

# External Accessories



## Safe-T-Step

P/N: #40011035

**Dimensions** 380W x 40H x 160D

**Weight** 5kg



## Flow Through Roof Vent

P/N: #RVFT

**Dimensions** 55H x 285L x 185W

**Weight** 0.5kg

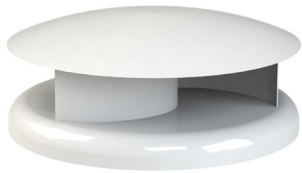

## Low Profile Spinning Roof Vent

P/N: #RVSP

**Dimensions** 55H x 252D

**Weight** 1kg



## Suspension GVM Upgrade

P/N: #40003509/44004156/59/61

**Weight** 15kg



## Suspension Leaf Spring Upgrade

P/N: #44004154/54/56/57/58/60

**Weight** 10kg

With rear leaf spring upgrade



## Commercial Bar

P/N: #COMMBAR

**Dimensions** Vehicle Specific

**Weight** 70kg





### Spartan Bar

P/N: #SPARTANBAR

**Dimensions** Vehicle specific

**Weight** 35kg



### Runva Premium

P/N: #RVFT

**Dimensions** 200H x 160L x 573W

**Weight** 30kg



### Alloy Nudge Bar

P/N: #ANB

**Dimensions** Vehicle specific

**Weight** 35kg



### Black Grab Handle

P/N: #HGB

**Weight** 0.5kg

# Cab Accessories



## HD Seat Covers Driver & Passenger

VEHICLE SPECIFIC

**Dimensions** Vehicle Specific

**Weight** 1.5kg



## HD Seat Covers Driver, Passenger & Rear Seat Squabs

VEHICLE SPECIFIC

**Dimensions** Vehicle Specific

**Weight** 1.5kg



## HD Seat Covers Rear

VEHICLE SPECIFIC

**Dimensions** Vehicle Specific

**Weight** 3.5kg



## Deep Dish Rubber Mats x 4

P/N: #44002006

**Dimensions** Vehicle Specific

**Weight** 5kg



## Tablet Holder

P/N: #52005268

**Weight** 1.5kg

Adjustable carbon fibre mount



## Laptop Holder

P/N: #52005269

**Weight** 1.5kg

Adjustable seat bolt mount

# Cab Accessories

---



## Fire Extinguisher 1kg

P/N: #80001005

---

**Dimensions** 420H x 110D

---

**Weight** 1kg

---



## Fire Extinguisher 4.5kg

P/N: #98005205

---

**Dimensions** 560H x 145D

---

**Weight** 4.5kg

---

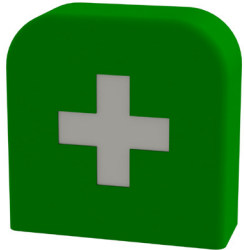

## First Aid Kit Large

P/N: #50001029

---

**Weight** 0.5kg

---

# Internal Accessories



## 20L Water Container & Floor Mount

P/N: #20LWATER

**Dimensions** 320W x 420H x 320D

**Weight** 3.5kg



## Load Restraint Track with 2 Eyelets

P/N: #ANCHORTRACK

**Dimensions** 2000m long

**Weight** 1kg

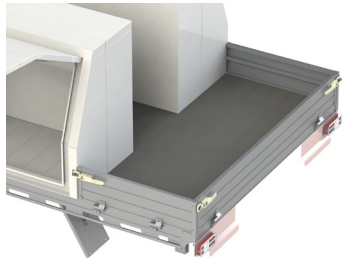

## Rubber Matting for Service Body Deck

P/N: #RUBFLSWBVK

**Dimensions** Body Specific

**Weight** 10kg



## Rubber Matting for False Floor

P/N: #RUBMATFF

**Dimensions** Body Specific

**Weight** 10kg

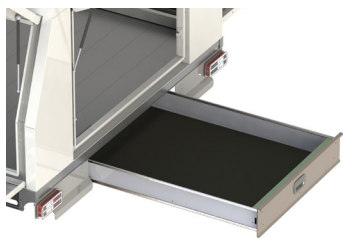

## Rubber Matting for Under Deck Drawer

P/N: #RUBMATUDD

**Dimensions** Body Specific

**Weight** 8kg

# General Accessories

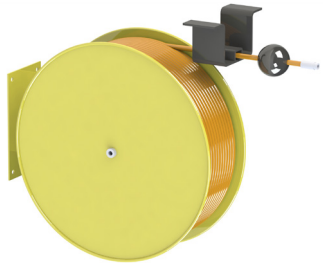

## Retracting Air Reel

P/N: #50005262

**Dimensions** 15m

**Weight** 12kg

12.5mm x 15M Koreel

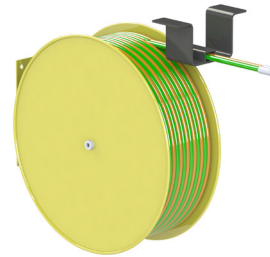

## Retracting Oxyacetylene Reel

P/N: #52005267

**Dimensions** 15m

**Weight** 15kg

12.5mm x 15M Koreel



## Air Compressor

P/N: #C-PAB16P

**Dimensions** 700H x 850L x 350W

**Weight** 73kg

PAB16, 16.6CFM, 130PSI



## 25L Tank Underdeck Mount

P/N: #AIRTANK-25L

**Dimensions** 350H x 700L x 300W

**Weight** 9kg

Front/rear side



## 40L Tank Underdeck Mount

P/N: #AIRTANK-40L

**Dimensions** 450H x 700L x 400W

**Weight** 6kg

Front/rear Side

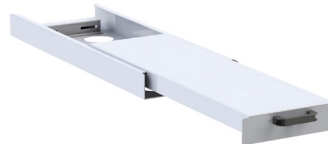

## Generator Slide SLI950

P/N: #GSLI950

**Dimensions** 100H x 950L x 350W

**Weight** 15kg

# General Accessories

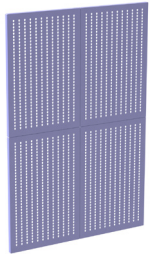

## Tool Clips / Perforated Panel

P/N: #TOOLPANEL

**Dimensions** 600mm x 400mm



## Cable Holders for Extension Leads

P/N: #CABLE

**Weight** 2kg

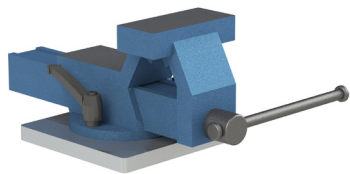

## Vice on Swivel Platform

P/N: #MOG4S

**Dimensions** 110mm

**Weight** 14kg



## Aerosol Spray Holder

P/N: #AEROSOL-8

**Dimensions** 340W x 220H x 210D

**Weight** 0.5kg

Holds 8 Cans

# Cranes



## PH150.3 Crane

P/N: #PH150.3

**Dimensions** 1360H x 790W

**Weight** 280kg

150.3 ERS 12-D Crane, up to 990kg lifting capacity at 1.2M and 350kg at 4M



## PH50.2 Crane

P/N: #PH50.2 ERS12

**Dimensions** 1060H x 510W

**Weight** 95kg



## Knuckle Joint Crane

P/N: #KJ250/1.5

**Dimensions** 995+H x 905W

**Weight** 42kg



Maximise the ease of safely lifting heavy loads 75kg+ onto the back of your vehicle with a great range of modular cranes. Maxilift cranes are light, high tech, and easy to use.

# Windows



## Sliding Bonded Finish

P/N: #LEDINT1000

**Dimensions** Vehicle specific

**Weight** 8kg



## Fixed Bonded Finish

P/N: #LEDINT500

**Dimensions** Vehicle specific

**Weight** 5kg



## Tinting

P/N: #LEDINT150

**Dimensions** Vehicle specific

All rear windows, large vehicle

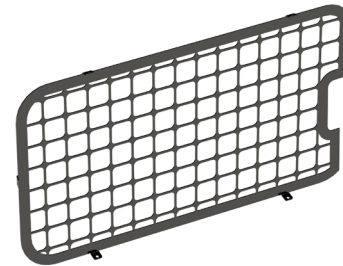

## Security Mesh Window Protection

P/N: #LEDSLIM

**Dimensions** Vehicle specific



# Electrical



## LED Internal Light 1000mm

P/N: #LEDINT1000

**Dimensions** 5H x 20W x 1000L

**Weight** 1kg

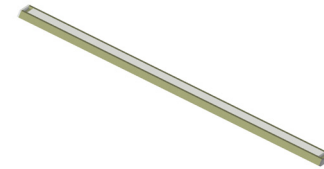

## LED Internal Light 500mm

P/N: #LEDINT500

**Dimensions** 5H x 20W x 500L

**Weight** 1kg



## LED Lighting in Cab 150mm

P/N: #LEDINT150

**Dimensions** 5H x 20W x 150L

**Weight** 1kg

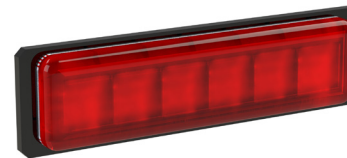

## Slim Line Warning Light

P/N: #LEDSLIM

**Dimensions** 5H x 20W x 150L

**Weight** 1kg



## LED Warning Corner Light

P/N: #50005251

**Dimensions**

**Weight** 0.5kg

180 degree visibility

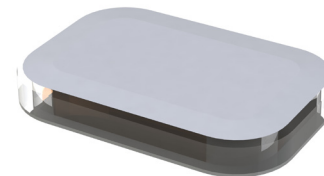

## Front Mount Led Bar Light Small

P/N: #LEDBARSML

**Dimensions** 37H x 172W x 248L

**Weight** 1.5kg

# Electrical

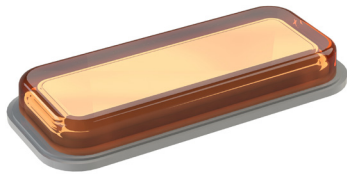

## Front Mount Led Bar Light Large

P/N: #LEDBARLRG

**Dimensions** 75H x 160W x 420L

**Weight** 2kg



## LED Beacon – Class One 150Mm

P/N: #LEDROUND1

**Dimensions** 150H x 120D

**Weight** 1kg



## LED Flood / Worklight

P/N: #LED FLOOD

**Dimensions** 115D

**Weight** 1kg



## LED Beacon Magnetic Mount

P/N: #50001107

**Dimensions** 150H x 120D

**Weight** 1kg



## LED Spot Light Magnetic Mount

P/N: #52005279

**Dimensions** 115D

**Weight** 1kg



## Spot Light 3500lmn

P/N: #LED SPOT

**Dimensions** 115D

**Weight** 1kg



### LED Remote Stryker Spot Light

P/N: #LEDREMOTE

**Weight** 1.5kg

1300Lm, 370 Degree Rotation, 135 Degree Tilt



### Reversing Camera

P/N: #RCAM-EX-SCREEN

**Weight** 0.5kg

Coupled Into Existing Dash Screen



### Reversing Sensors X 4

P/N: #RSENSORS

**Weight** 1kg



### Reversing Camera with Mirror

P/N: #RCAMMIRROR

With Rear Vision Mirror Screen



### Self Adjusting Reversing Beeper

P/N: #RBEEPER

**Weight** 1kg

77-102DB, 12-24V IP67



### 4 Star Vehicle Alarm System

P/N: #ALARM-4STAR

**Weight** 1kg

# Electrical



## Box Body Door Alarm

P/N: #ALARM-BB3D

**Weight** 1kg

For 3 Doors

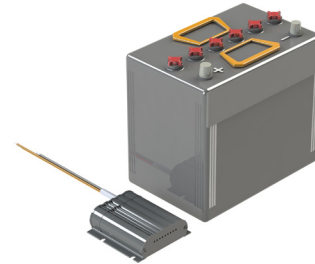

## Battery & Charge Kit U1

P/N: #INVBM-U1

**Weight** 25kg

20A Charger Unit, 31DC battery for ute wellside/ service body

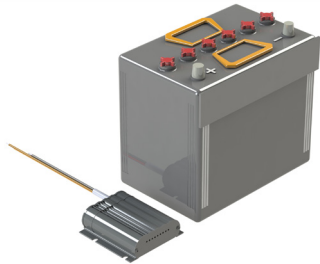

## Battery And Charge Kit U2

P/N: #INVBM-U2

**Weight** 25kg

20A Charger Unit, 31DC Battery, inverter under passenger seat/battery in ute service body

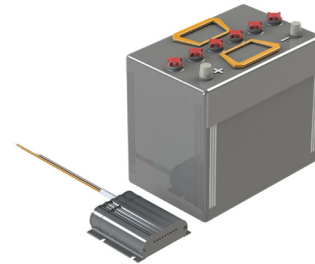

## Battery And Charge Kit VF

P/N: #INVBM-VF

**Weight** 25kg

20A Charger Unit, 31DC battery for van behind bulkhead

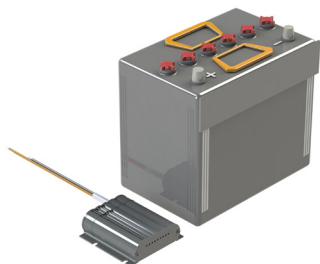

## Battery And Charge Kit VR

P/N: #INVBM-VR

**Weight** 25kg

20A Charger Unit, 31DC battery for van mid rear cargo mount

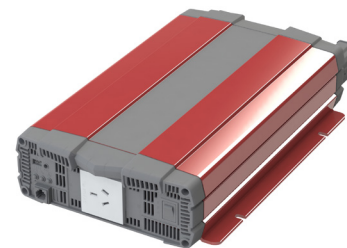

## Redarc Inverter 1500W

P/N: #50005277

**Dimensions** 83H x 248W x 421L

**Weight** 4.5kg

12-240V- Pure Sine Wave

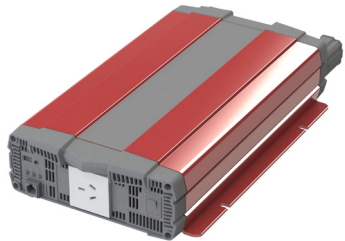

### Redarc Inverter 2000W

P/N: #50005250

**Dimensions** 83H x 248W x 443L

**Weight** 5.25kg

12-240V– Pure Sine Wave

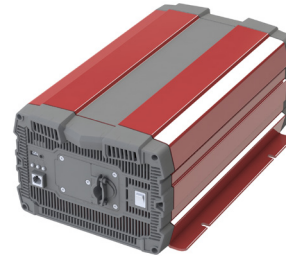

### Redarc Inverter 3000W

P/N: #50005272

**Dimensions** 158H x 255W x 442L

**Weight** 4kg

12-240V– Pure Sine Wave

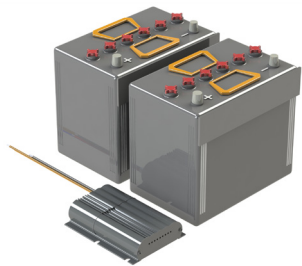

### 31DC Batteries & Charger

P/N: #2BATT31DC-50AC

**Weight** 40kg

2 X Batteries 31DC With 50A Battery Charger



### Underdeck Swivel LED Light

P/N: #LEDUDS

**Weight** 5kg



### Auto Transform Switch Module

**Weight** 1kg

**“I can honestly say that the Auto Transform team are second to none.”**

Wayne Perkins, Electrix





**MIX**  
Paper from  
responsible sources  
**FSC® C107054**

This publication is printed on environmentally responsible paper produced from FSC® Certified Mixed Source pulp from Responsible Sources.



Auto Transform Limited  
3 Harbour Ridge Drive  
Stone Hill Business Park  
Wiri, Auckland 2104  
09 580 0477 | [sales@autotransform.co.nz](mailto:sales@autotransform.co.nz)



**Transform your workspace.  
Talk to a vehicle fitout expert today.**

**[autotransform.co.nz](https://autotransform.co.nz)**