

ACCESS
HOIST 5000AL

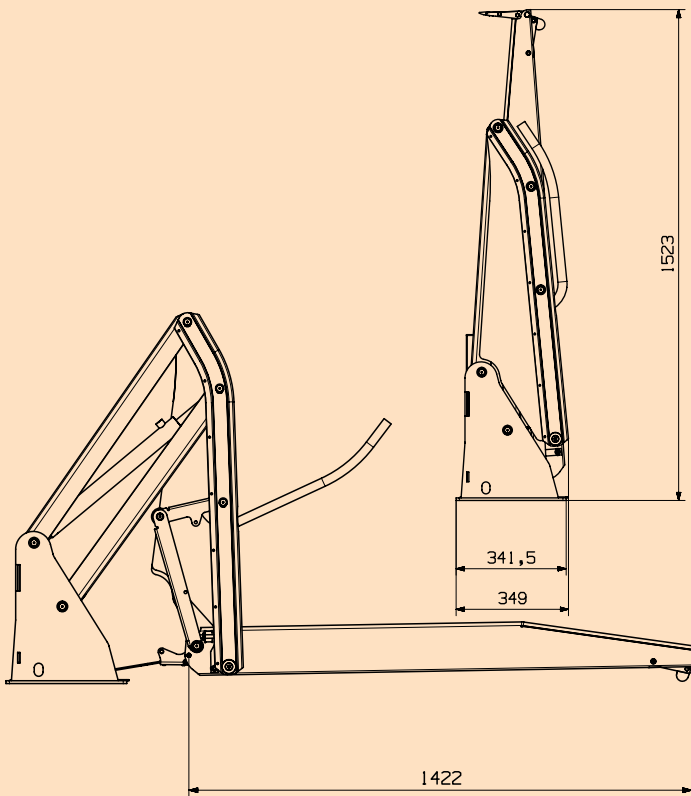

ACCESS HOIST 5000AL

**AUTO
TRANSFORM
MOBILITY
ENHANCEMENT**



Mobility Enhancement Wheelchair Platform Hoist 5000AL is a fully aluminium light weight lift. Its state of the art design provides a great professional finish as well as providing great benefits with significant weight reduction.

FEATURES:

- Safe working load of 350 kg
- Easy to operate
- Emergency auxiliary manual pump
- All aluminium making it very light weight
- Platform closes on rubber buffers when stowed to prevent rattling
- Made 100% recyclable materials making this hoist very eco-friendly

BENEFITS:

- Less than 100 kg reducing fuel consumption
- Fully Certified to New Zealand Safety Standards and crash tested for your assurance and peace of mind
- Guarantee of security, reliability with product warranty of 3 years
- Back up service and parts to ensure minimum downtime of your operations



Anti-slip mesh platform



Full load platform



All aluminium

